

**MINISTRY OF GENERAL EDUCATION  
NORTHERN PROVINCE  
PROVINCIAL COMMON EXAMINATION  
QUESTIONS WITH ANSWERS**

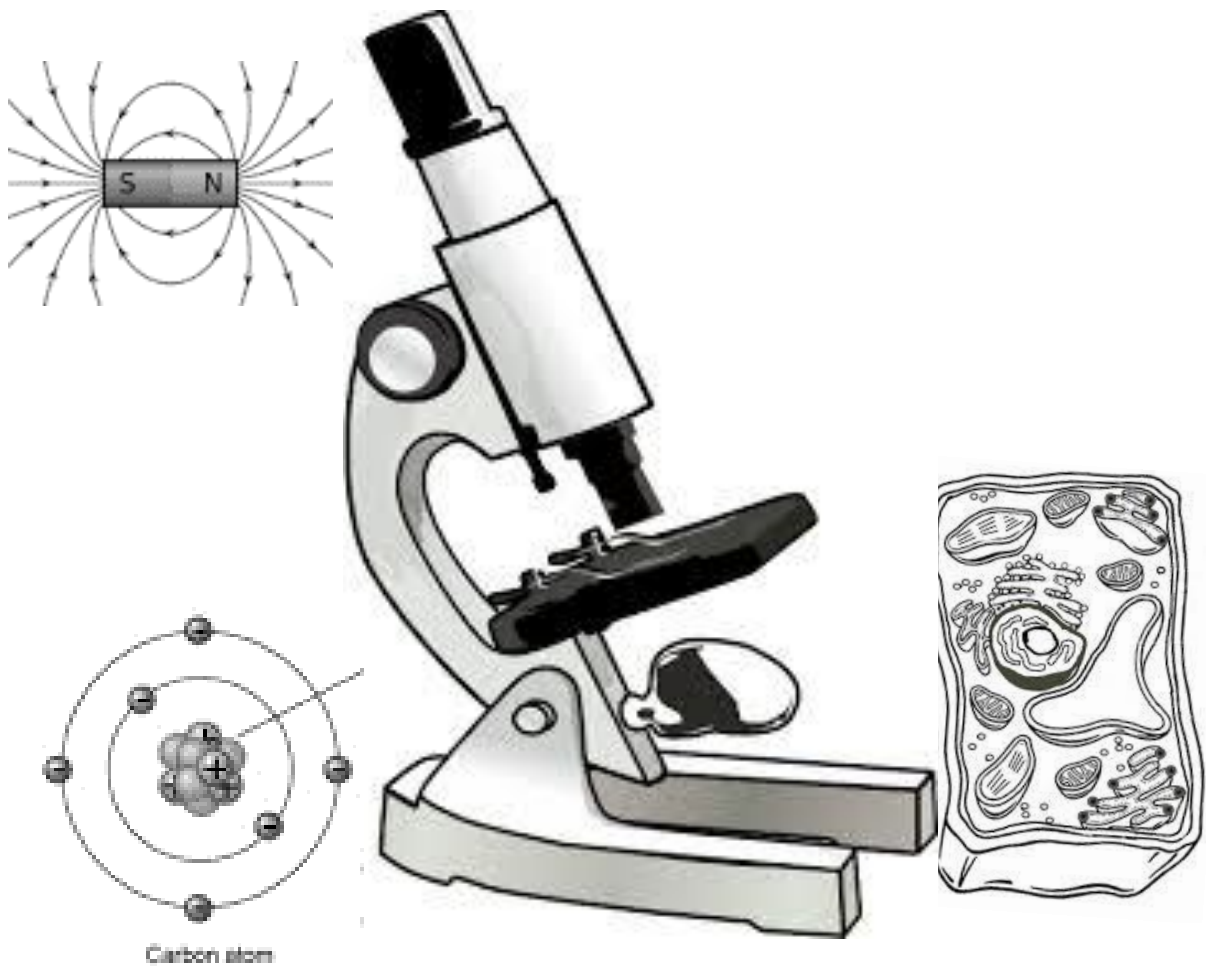

**INTEGRATED SCIENCE**

**First Edition, 2016**

# TABLE OF CONTENT

## 1.0 GRADE EIGHT (8)

1.1 THE HUMAN BODY .....	1
1.2 HEALTH .....	3
1.3 THE ENVIRONMENT .....	4
1.4 PLANTS AND ANIMALS .....	5
1.5 MATERIALS AND ENERGY .....	7
1.5.1 COMPOSITION OF AIR .....	7
1.5.2 PHYSICAL CHANGE .....	8
1.5.3 MIXTURES .....	8
1.5.4 MASS AND WEIGHT .....	10
1.5.5 DENSITY .....	11
1.5.6 HEAT TRANSFER .....	13
1.5.7 COMPOSITION OF AIR .....	15

## 2.0 GRADE NINE (9)

2.1.1 CIRCULATORY SYSTEM .....	16
2.1.2 RESPIRATORY SYSTEM .....	18
2.2 HEALTH .....	19
2.3 THE ENVIRONMENT .....	20
2.4.1 CYCLES IN THE BIOSPHERE .....	20
2.4.2 WATER MANAGEMENT .....	21
2.4.3 CONSERVATION OF ANIMALS AND PLANTS .....	21
2.4.4. PHOTOSYNTHESIS .....	21
2.4.5 TRANSPIRATION .....	22
2.5.0 MATERIALS AND ENERGY .....	23
2.5.1 CHEMICAL REACTIONS .....	23
2.5.2 LIGHT AND ITS NATURE .....	23
2.5.3 REFLECTION AND REFRACTION OF LIGHT .....	23
2.5.4 ELECTRIC CURRENT AND VOLTAGE IN CIRCUIT .....	26

2.5.5 PRESSURE .....	29
2.5.6 ENERGY AND ITS CONSERVATION .....	30
2.5.7 COMMUNICATION .....	30
2.5.8 DIGITAL AND ANALOGUE TRANSMISSION .....	30
SUGGESTED ANSWERS - GRADE EIGHT (8) .....	32
30SUGGESTED ANSWERS - GRADE NINE (9) .....	46

## THE HUMAN BODY

### QUESTION ONE

- i. What do we call a group of interacting, interrelated or interdependent elements forming a complex whole?
- ii. What name is given to the part of the body which carries out a specific function?
- iii. Name the process by which living organisms produce their young ones.
- iv. The following are male reproductive organs.

1. Sperm duct 2. Testis 3. Epididymis 4. Urethra

Using the given numbers, show the correct path taken by the sperm before it is finally ejaculated.

- v. A Woman has a pregnancy which is 30 weeks old. How many weeks is she remaining with in order for her to complete the normal gestation period?

### QUESTION TWO

Study the diagram showing the male reproductive system.

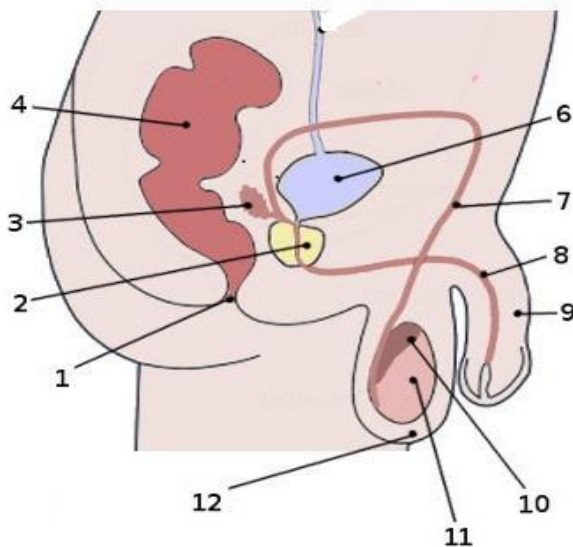

- i. Identify the following parts; 2, 3, 6, 7, 8, 9, 10 and 11.
- ii. Explain the functions of the following parts: 2, 3, 6, 7, 8, 9, 10, and 11
- iii. Give the other name of the sperm duct.
- iv. Name one substance produced by the organ labelled 11 .
- v. Suggest what could happen when the substance produced by structure 11 you have mentioned in (v.) above meets the ovum in the fallopian tube.
- vii. Explain the importance of observing personal hygiene of the reproductive organs.

### QUESTION THREE

Study the diagram showing the male reproductive system.

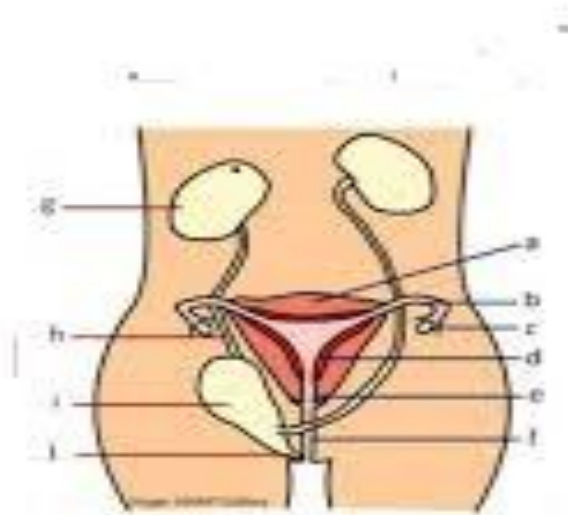

- i. Name the parts labelled a, b, c, e and f.
- ii. Explain the functions of the parts a, b, c and f.
- iii. Identify the organ that produces the female sex cells or gametes?
- iv. In which part of the female reproductive organ does fertilisation occur?
- v. Explain how the process of fertilisation takes place .
- vi. Where does the embryo develop?

### QUESTION FOUR

The diagram below shows the development of an embryo. Study the diagram below to answer the question that follows.

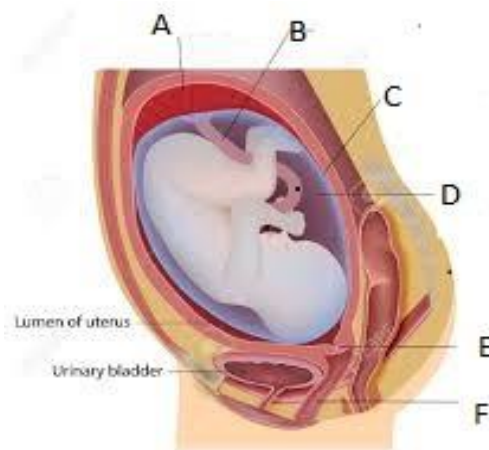

- (a) Mention the parts labelled A, B, C, D, E and F.
- (b) Explain the functions of each part shown above.
- (c) What do you understand by the term gestation period?
- (d) Briefly describe the process of labour.
- (e) Describe what happens to the position of the baby between sixth and eighth month from the day of fertilisation?
- (f) Give any three methods of birth control.
- (g) Write four parental cares before and after birth.
- (h) If a woman conceives on 23 May, Predict the birth date of her baby.
- (i) If the woman conceived on 4 April and the baby was born 5 December, was the birth date earlier or later than predicted? Explain the answer.

#### QUESTION FIVE

- (a) Explain the meaning of puberty.
- (b) Why is puberty important in human beings?
- (c) What are the sex hormones?
- (d) Which organ in female and male produce sex hormone.
- (e) Mention and explain how the hormone produced in the female and male organs work.
- (e) Describe the changes that take place in both female and male at puberty.

### 1.2. HEALTH

#### QUESTION SIX

- (a) Define the term nutrient.
- (b) State the seven classes of nutrients important to human beings.
- (c) Why are these nutrients important to human being?
- (d) Describe the dietary needs for:
  - (i.) Sick people, (ii). Pregnant mother (iii). Lactating woman
  - (iv). Manual worker (v). Elderly people and (vi). Sedentary workers.
- (e) The table below show the sources of the nutrients and the effect of deficiency .Fill in the missing spaces.

Food nutrient	Sources of food nutrients	Lack of it causes
Vitamin A		
		Rickets
Lipids		
Carbohydrates		
		Constipation

		Anaemia
Vitamin C		
	Iodised table salt, sea foods	
Iron		
		Kwashiorkor

## QUESTION SEVEN

- What information does a children's card give?
- Explain the importance of the under- five clinic.
- Using the information in the table plot mass - age graph.

Mass (Kg)	3	4	5	6.5	6.5	8	4
Age(months)	1	2	3	4	5	6	7

- What happens to the weight from month one to month three.
- Explain what happened to the baby from month four to month five.
- What could have led to the weight to drop in month 7?
- Name three of the most common causes of poor health in children in the age group of zero to five years.
- From the graph on the children's clinic card, determine :

**1.3 THE ENVIRONMENT**

## QUESTION EIGHT

- Explain what pollution is.
- Explain different types of pollution of the environment.
- Identify causes of the types of pollution mention in (c) above on the environment.
- Describe the effect of land, air and water pollution.
- Explain how acid rain is formed.
- How does air pollution cause global warming?
- Imagine that you are a Local government officer, describe ways you can use to prevent pollution in your environment.
- What is eutrophication?

## QUESTION NINE

Study the diagram below and answer the questions that follow.

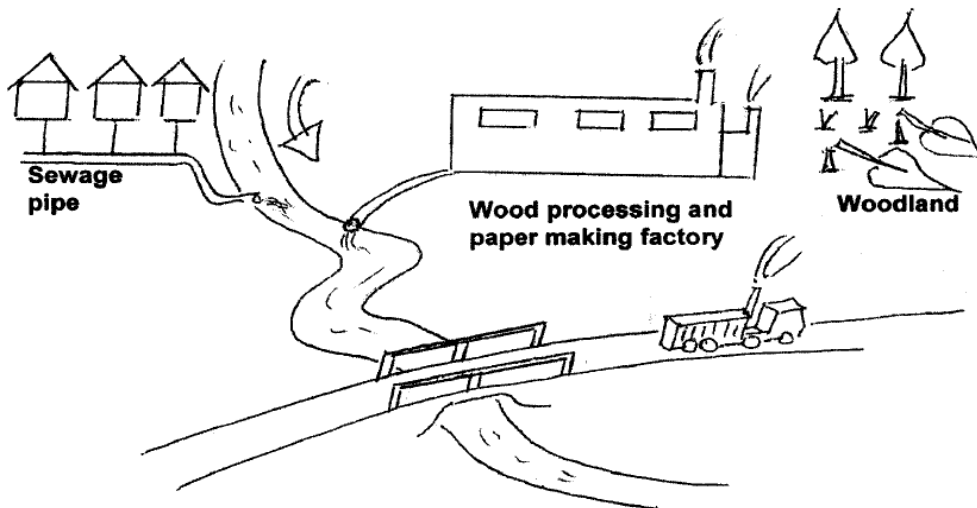

- i. Identify the diminishing resource being used in the above diagram.
- ii. Which two man's activities shown in the above diagrams have a negative impact on the environment?
- iii. Suggest one solution to any of the identified activities which have a negative impact on the environment.
- iv. In which way would the paper making factory help in the conservation of the environment?
- v. Give an explanation as to why the Zambian government has formed monitoring bodies such as the Examinations Council of Zambia.
- vi. Predict the type of pollution being introduced by the moving truck in the above diagram.

#### 1.4 PLANTS AND ANIMALS

##### QUESTION TEN

1. Study the diagram below and use it to answer the question.

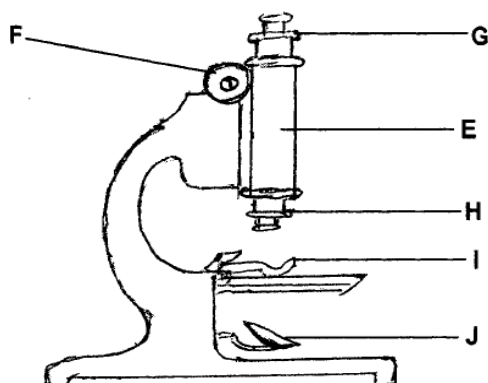

- (a) Identify the parts labelled E, F, G, H, I and J
- (b) Explain the functions of the parts labelled E, F, G, H, I and J.

- (c) Describe how a microscope can be used to examine cells in an onion.
- (d) What is the importance of using the microscope on small object?.
- (e) Name any two devices that use microscopes.

### QUESTION ELEVEN

Study the diagrams below showing the regions of active growth in plants.



- a. What name is given to the regions of active growth in plants?
- b. From which parts of a plant is A and B removed from?
- c. Describe the three regions of growth that are found in plants.
- d. Which of the two above is (i). Positive geotropic? (ii) Positive phototropic?

### QUESTION TWELVE

Study the diagram below and answer the questions that follow

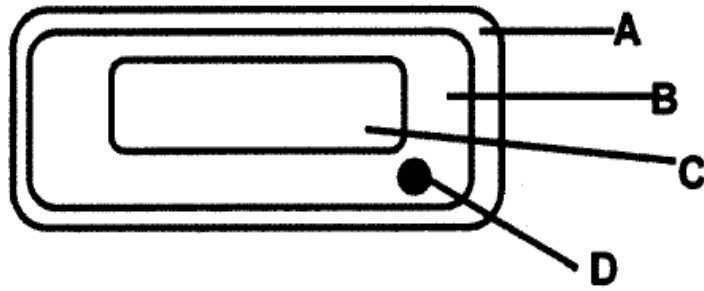

- Name the parts labelled A, B, C and D
- Which labelled part controls all cell activities?
- In which of the labelled parts of the cell above can you find cell sap?
- List three parts of a cell which make up the protoplasm.
- Compare the animal cell with the cell shown above. Give any three similarities and differences.

#### QUESTION THIRTEEN

- list any three stimuli that plants respond to.
- What causes roots to grow downwards?
- Why are tropisms important to plants?
- Write the advantage of tropisms to farmers.

#### QUESTION FOURTEEN

The diagrams below show three potted plants A, B and C to observe the growth response of plant to stimuli. The two plants A and B have been growing for five days. A and B are covered with a box with a hole facing a window. Plant C is placed side-ways.

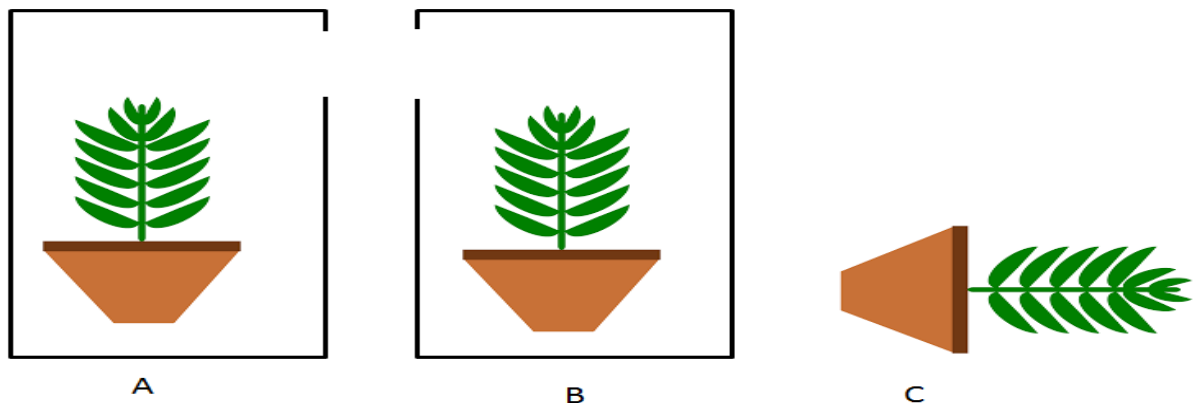

- What stimulus is being observed in A and B?
- Draw diagrams to show the growth direction of A and B respectively.

- c. Give conclusion that you have drawn from the above experiment of plant A and B?
- d. Name the stimulus being observed in plant C.
- e. Construct a diagram to show the growth of plant C.
- f. What conclusion can draw from the above experiment of plant C?

## **1.5. MATERIALS AND ENERGY**

### **1.5.1 Composition of matter**

#### QUESTION FIFTEEN

- a. Define the term matter.
- b. Describe the composition of matter.
- c. Explain the difference between a molecule and an atom.
- d. Give four examples of elements and name the atoms/particles that make up the elements
- e. What are the chemical symbols of the following?
  - i. chlorine
  - ii. Aluminium
  - iii. Copper
  - iv. Hydrogen
  - v. phosphorus
- f. write the names of the elements represented by the following symbols:
  - i. Ca
  - ii. Na
  - iii. K
  - iv. Be
  - v. Br
  - vi. Si
  - vii. Fe
  - viii. Mg
- g. How do elements in the free state differ from those in the combined state?

### **1.5.2. Physical change**

#### QUESTON SIXTEEN

- a. Name the three states of matter.
- b. Describe the arrangement and movement of particles in the three states of matter.
- c. Study the graph of temperature against time below and answer the questions that follow.

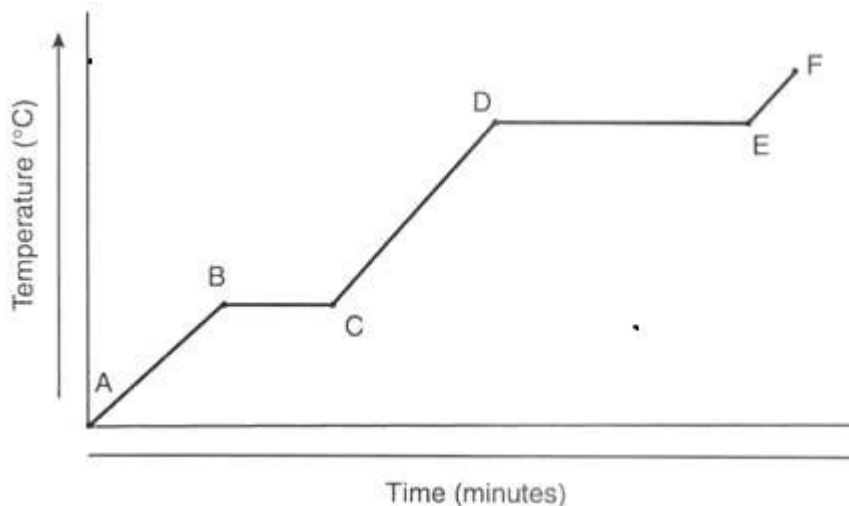

- I. At what stage of the graph was the temperature of the steam increases steadily as the heat increases?
  - II. At what stage was did the temperature increase until the boiling point was reached?
  - III. Name the stage in the graph at which the temperature of ice rises steadily as heat is absorbed by ice.
  - IV. Identify the stage at which the temperature remains constant until the liquid has completely vaporized.
- d. What is meant by the term sublimation?

### 1.5.3 MIXTURES

#### QUESTION SEVENTEEN

- a. Define the term mixture.
- b. Give any four examples of mixtures.
- c. Design an experiment to show distillation of common salt.

#### QUESTION EIGHTEEN

Study the diagram below and answer the questions that follow:

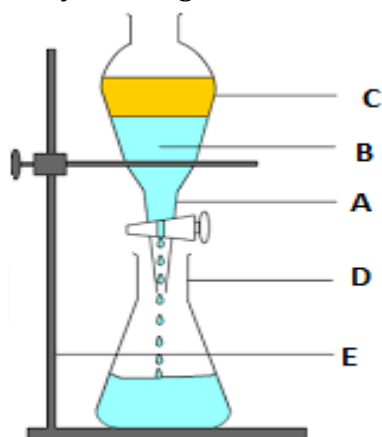

- What name is given to the apparatus marked A and D
- Identify the method of separating mixture shown above.
- Give the type of mixture separated using this mixture.
- Explain how a mixture is separated using this method.
- What method can you use to separate each of the following mixtures?
  - Salt from sea water
  - Water and alcohol
  - Iron fillings and saw dust.

### QUESTION NINETEEN

Study the diagram below showing a separation technique

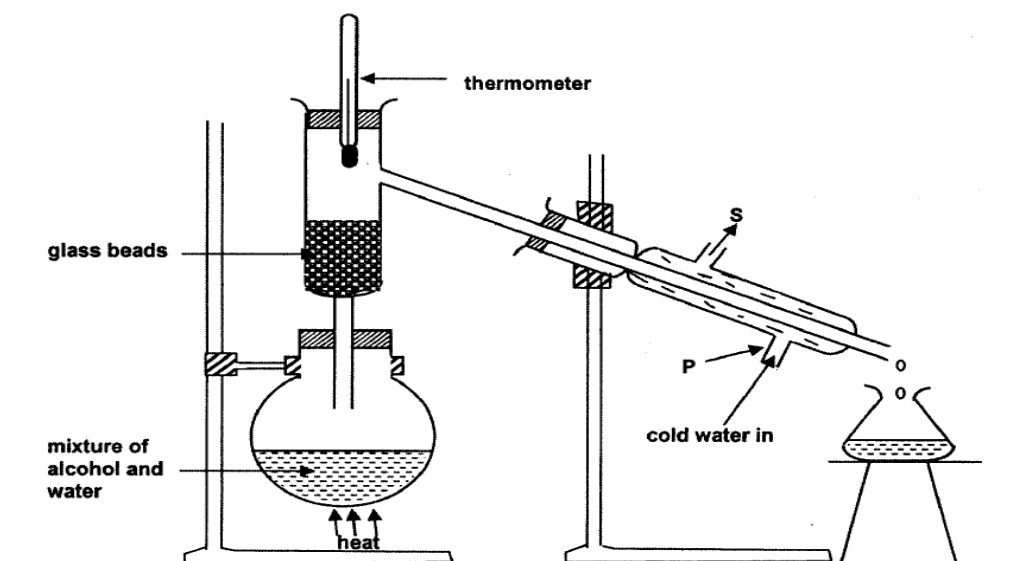

- Which separation technique is shown in the above diagram?
- Why should there be a constant supply of cold water through tube P?
- Give one industrial application of the above separation technique.
- Describe the function of the following in the above experiment:
  - Thermometer
  - Glass beads
- What physical property of substances in the mixture makes it possible for them to be separated in this method?

### QUESTION TWENTY

Study the diagram below showing a mixture being separated in three stages.

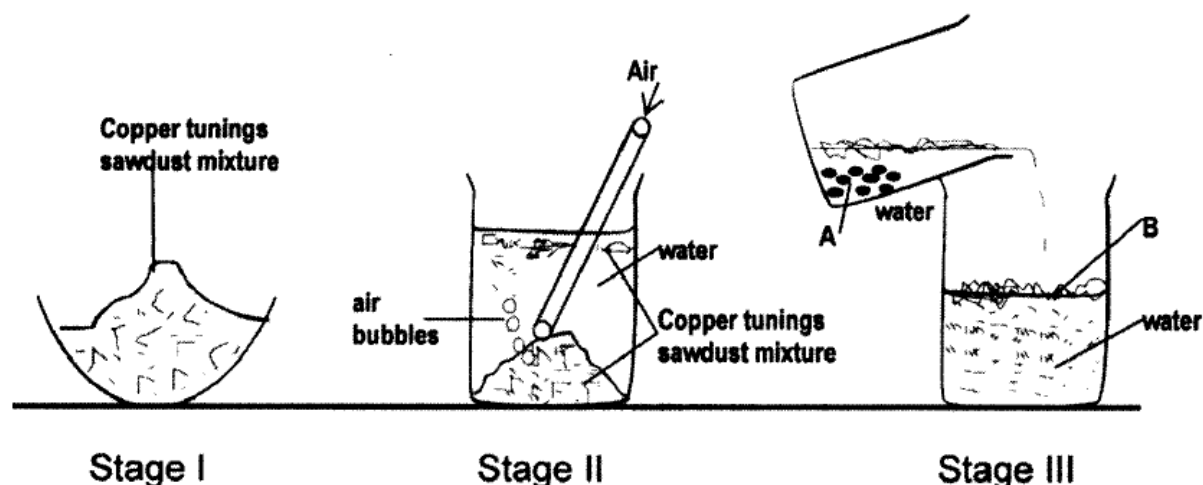

- Suggest the method of separation shown by diagrams from stage I to III.
- State two properties required to make the separation by the method you have mentioned in (a) above.
- Apart from blowing the air through the mixture as shown in stage II, suggest the other thing that can be done to improve the separation of copper and saw dust mixture.
- The method of separation shown in the diagrams can also be used to separate a mixture of iron and saw dust, suggest another method by which you can separate iron and saw dust mixture.

#### QUESTION TWENTY ONE

- Design an experiment on how you can separate a mixture of sand and salt.

#### 1.5.4 MASS AND WEIGHT.

#### QUESTION TWENTY TWO

- Define the terms (i) mass and (ii) weight
- What is the SI unit for (i) mass and (ii) weight
- Discuss the differences between mass and weight

#### QUESTION TWENTY THREE

- Convert the following into kg  
(i). 30g (ii). 60g (iii). 200g (iv). 2000g (v). 5 tonnes
- Calculate the weight of an object whose mass is 20Kg
- What is the weight of a duster whose mass is 80g?
- Explain why the weight of an object varies from place to place.

#### QUESTION TWENTY FOUR

The diagram below shows masses whose mass was being measured.



- What is the mass of the masses?
- The instrument above is used to measure weight, name the instrument used to measure weight.
- Given that the acceleration due to gravity is  $10\text{N/Kg}$ , calculate the weight of the masses. (show all your working)
- Name the instrument used to measure weight.

### 1.5.5 DENSITY

#### QUESTION TWENTY FIVE

- Define the term density
- What is the SI unit for density?
- If the mass of a substance is  $M\text{ g}$  and its density is  $D\text{ g/cm}^3$  its volume can be expressed as .....
- If the volume of a substance is  $V\text{ cm}^3$  and its density is  $D\text{ g/cm}^3$  and its mass can be expressed as .....
- Given the mass  $M\text{ g}$  and the volume  $V\text{ cm}^3$ , the density can be expressed as .....

#### QUESTION TWENTY SIX

Study the diagrams on the experiment on density of a stone.

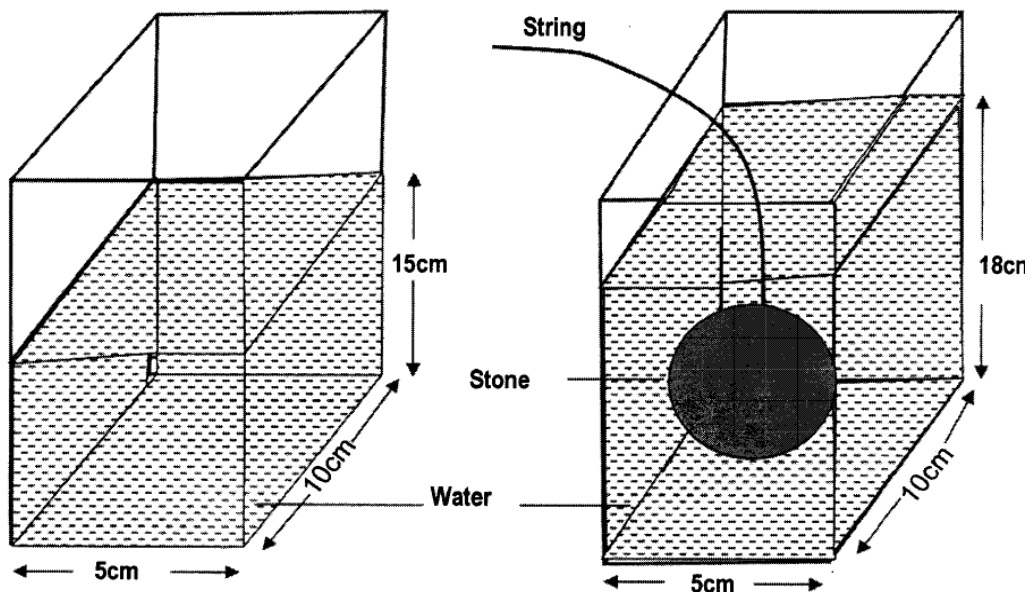

- Calculate the volume of water used in the experiment.
- What is the increase in height of water in the vessel after the stone was placed in it?
- Calculate the volume of the stone in the experiment.
- If the mass of the stone used is 300g, calculate the density of the stone (show all your working)
- Why could the experiment not be used to determine the density of a different solid of the same volume but mass of 50g?

QUESTION TWENTY SEVEN

The diagram below shows steps used to determine the density of a toy car

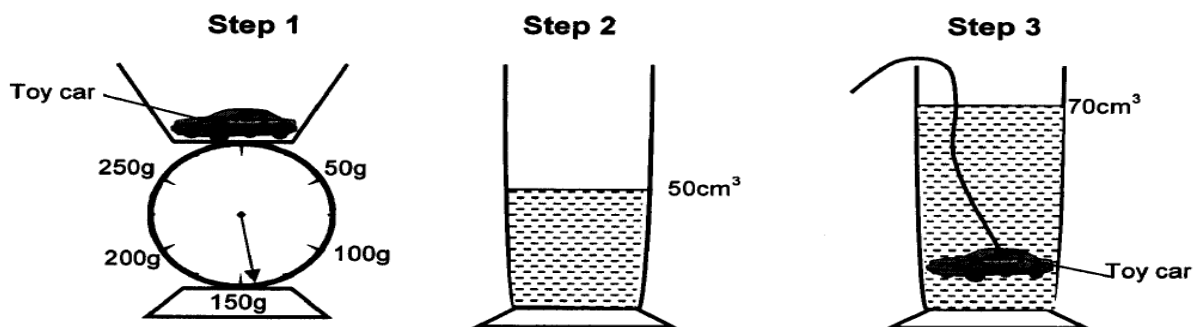

- Find the mass of the toy car.
- What is the volume of the toy car?
- Using the mass in (a) and (b), Calculate density of the toy. Show your working.
- Study the diagram below showing a block with an area of 35 cm<sup>2</sup> having its height measured.

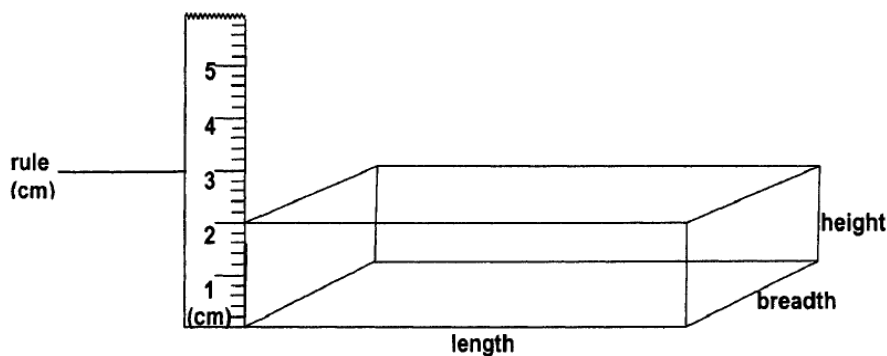

If the mass of the block is 280g, calculate the density of the block in  $\text{g/cm}^3$ .

QUESTION TWENTY EIGHT

- Given salt water and fresh water, where do you expect the egg to float?
- Give a reason for your answer in (a) above.
- Explain why ships and pontoons float on water though made of iron.
- Why should ships have plimsoll lines?

QUESTION TWENTY NINE

John wanted to determine the density of a liquid in a beaker of capacity of  $80 \text{ cm}^3$ .

- If the liquid in the beaker was filled to the capacity of the beaker, find the density of the liquid if its mass was 40g.
- What other apparatus could have been used to determine the volume of the liquid?
- The John plotted the results of a similar experiment to determine densities of two liquids in the graph shown below:

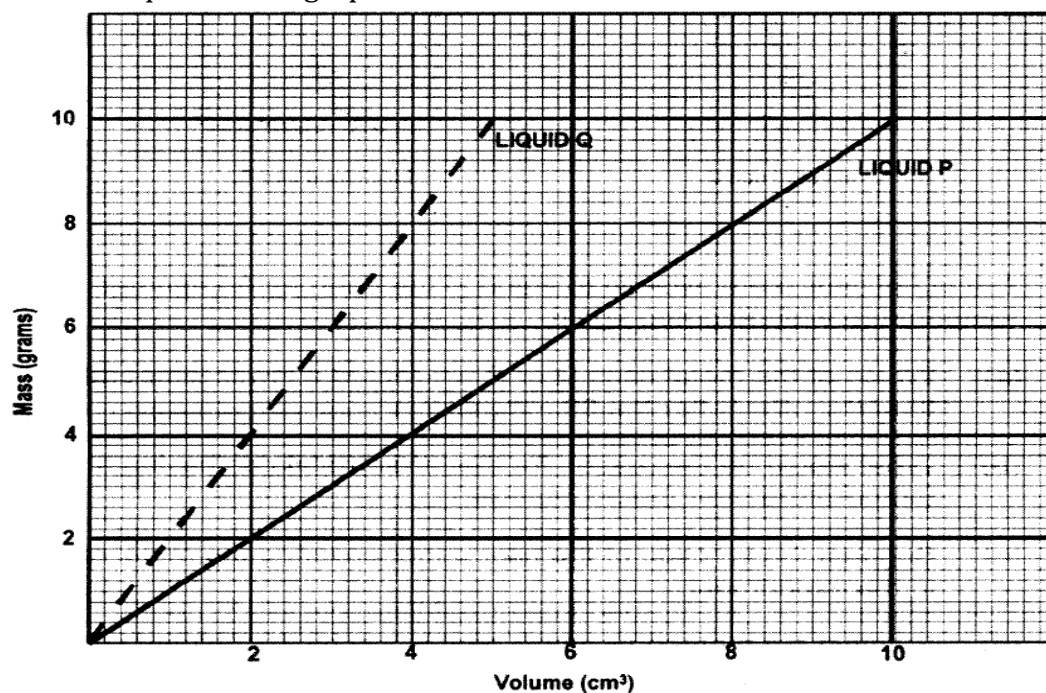

i). Which one of the two liquids P or Q will float on the other if the two liquids were put in one container and allowed to settle.

### 1.5.6 HEAT TRANSFER

#### QUESTION THIRTY

- Mention three ways in which heat can be transferred from its source.
- In conduction, heat is transferred from a hot region to a cold region by ..... Of particles.
- Non-metals such as glass, clothes, clay are ..... of heat.
- ..... is the transfer of heat through gases and liquids.
- Hot particles ..... and cold particles ..... to form convection current.
- Explain why hot air rises up.
- Where can you observe the effects of convection current in every day life?

#### QUESTION THIRTY ONE

Study the diagram showing the vacuum flask.

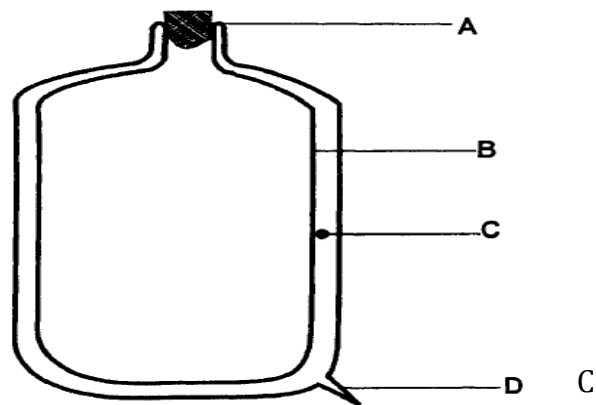

- Name the parts labelled A, B, and D.
- Why does a vacuum flask use glass inside?
- Explain why the glass vessel has a silver colour.
- Which two labelled parts prevent heat loss by conduction and convection?
- Identify the part which prevents heat transfer by conduction only.
- What is the function of the parts labelled A and D?
- Describe the importance of the apparatus shown above.

#### QUESTION THIRTY TWO

Study the diagrams showing two equal sized metal cans both containing hot water at 95°C.

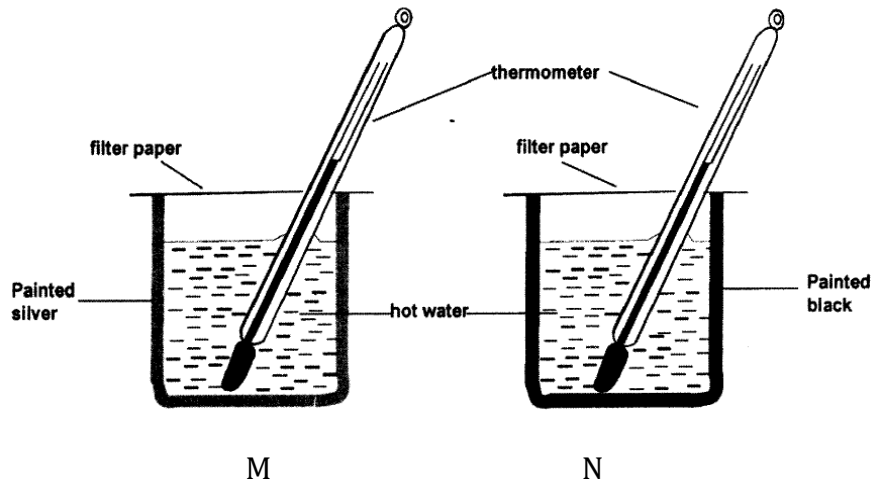

The metal cans were allowed to stand in the open for 40 minutes and then temperature recorded again.

- Which of the metal cans M or N will record a lower temperature than the other after 40 minutes.
- What could be the reason for the other metal can having the higher temperature after the 40 minutes?
- Suggest the function of the filter paper covering the metal cans in the above experiment.
- Mention the method by which heat is lost by the painted surfaces of the metal cans.
- What conclusion can be made in the above experiment?
- Explain why it is important to paint houses white or bright colours in very hot countries.

### QUESTION THIRTY THREE

Study the diagram below showing an experiment on heat.

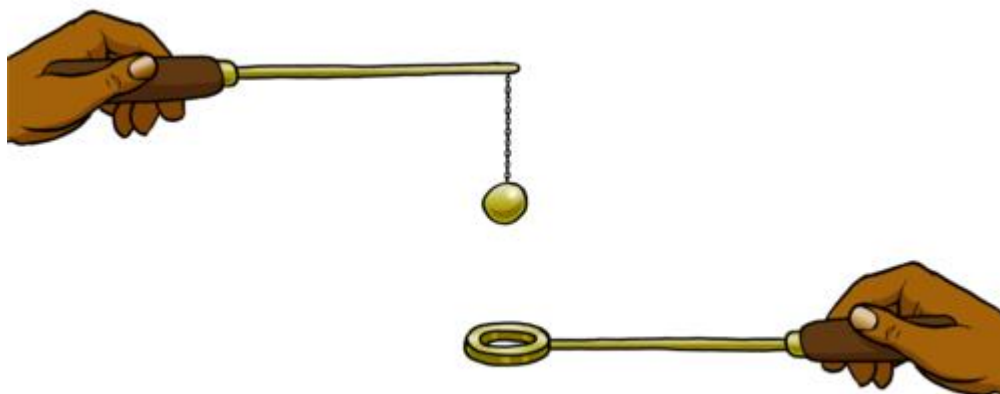

Before heating, an iron ball can pass through the ring.

(a) Will the ball pass through the ring after heated enough?

(b) Give the reason for your answer in (a) above.

(d) Explain why the handle attached to the ball is made up of wood.

### 1.5.7 COMPOSITION OF AIR

#### QUESTION THIRTY FOUR

- What is air?
- Identify the components of air.
- What is the approximate percentage composition of air by volume?
- Describe the physical properties of the following gases:
  - oxygen
  - Carbon dioxide
  - Nitrogen
- How are these gases mentioned in (d) above used in everyday life?

#### QUESTION THIRTY FIVE

Use the diagram below to answer the questions that follow:

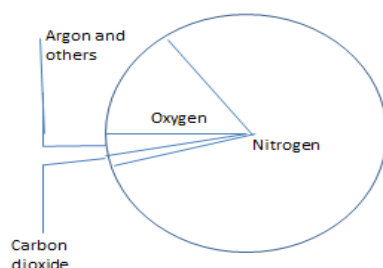

- Identify the most abundant gas in the atmosphere.
- Which elements make up the air we breathe?

- c. Name the gases we breathe in and out.
- d. What causes the drop in the amount of oxygen between inspired and expired air?
- e. Where in the body does oxygen join the red blood cells?

## 2.1.1 THE HUMAN BODY (CIRCULATORY SYSTEM)

### QUESTION ONE

- (a) Define the term circulatory system.
- (b) Identify the component of the circulatory system.
- (c) Explain the function of the component of the circulatory system mentioned above.
- (d) Mention the components of blood and discuss their functions.
- (e) Identify the three blood vessels
- (f) Describe the structure of three blood vessels mention above and explain their function.

### QUESTION TWO

1. Study the diagram below and answer the question that follows

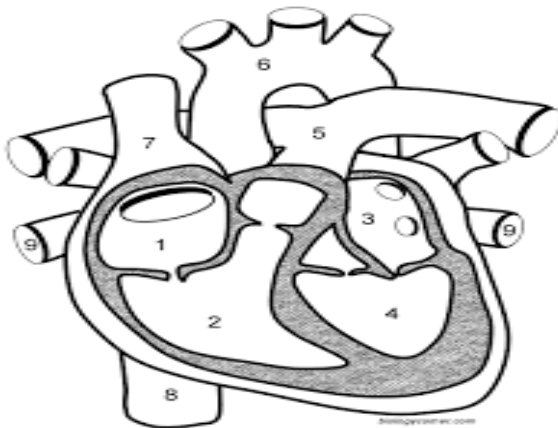

- (a) What system show by the above diagram
- (b) Name the chambers 1, 2, 3 and 4
- (c) Name the blood vessels 6, 7, 8 and 9 .
- (d) Why does blood pass through the lungs?
- (e) State the process that uses oxygen in the muscles.
- (f) Write the word equation represented by the process mention in (e).

### QUESTION THREE

The diagram below shows a system of a human body.

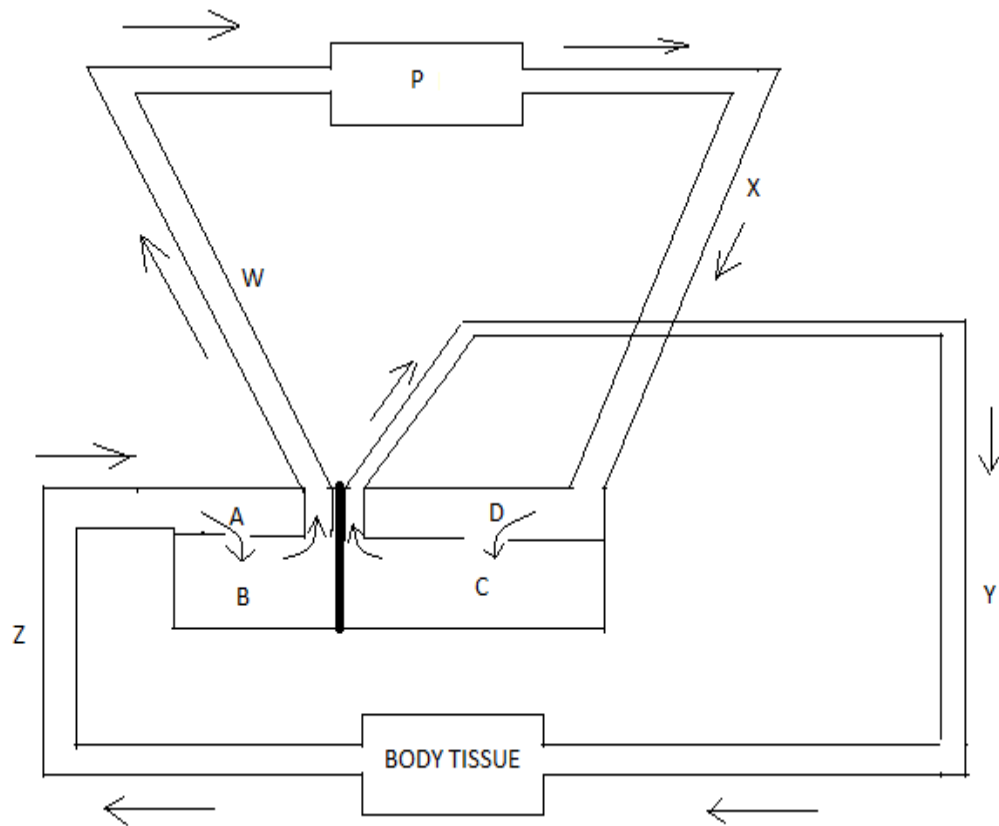

- Name the system shown above.
- Identify the chambers labelled A, B, C and D.
- Identify the blood vessels marked W, X, Y and Z
- Why does blood pass through organ P?
- State the difference between blood vessel Z and blood vessel Y.
- State the process that uses oxygen in the muscle.
- Explain why chamber C is thicker than chamber B.

#### QUESTION FOUR

Study the diagram and answer the questions that follow.

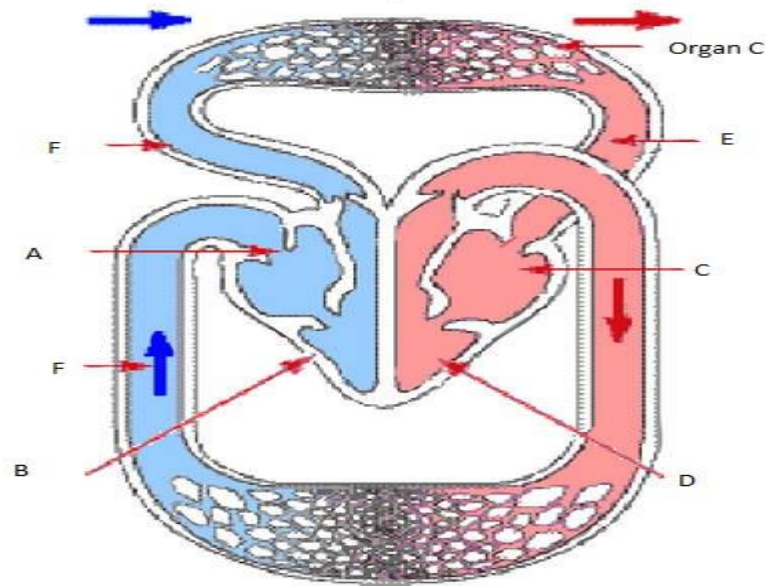

- What system is represented in the diagram above?
- Identify the following chambers: A, B, C, and D
- What is the function of the organ labelled C.
- What is the function of the heart?
- State one difference in appearance between the blood flowing in the vessels E and F.
- Identify the process that uses oxygen in the body tissue.
- Explain the meaning of the term double circulation.

### 2.1.2 RESPIRATORY SYSTEM

#### QUESTION FIVE

- The process of taking air in to the lungs from outside is called .....
- The process of pushing out air from the lungs is called .....
- What is the approximate percentage of carbon dioxide in the inspired air?
- What is the approximate percentage of oxygen in the expired air?
- State the term used to describe the amount of air that can be breathed out of the lungs after filling them completely.

#### QUESTION SIX

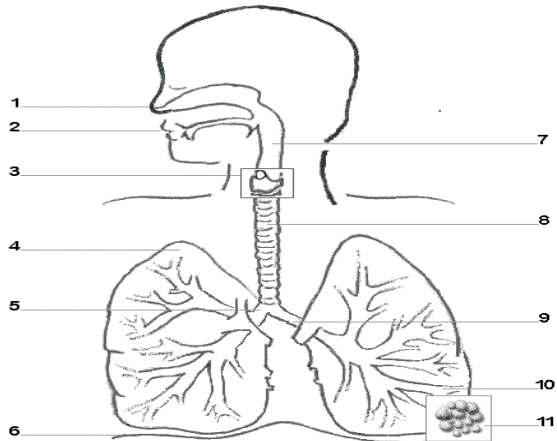

- (a) Identify the parts labelled 1-11.  
 (b) How is part 8 specialised to allow the free flow of air to and from the lungs.

QUESTION SEVEN

The diagram below shows a section of an alveolus and a capillary in a lung.

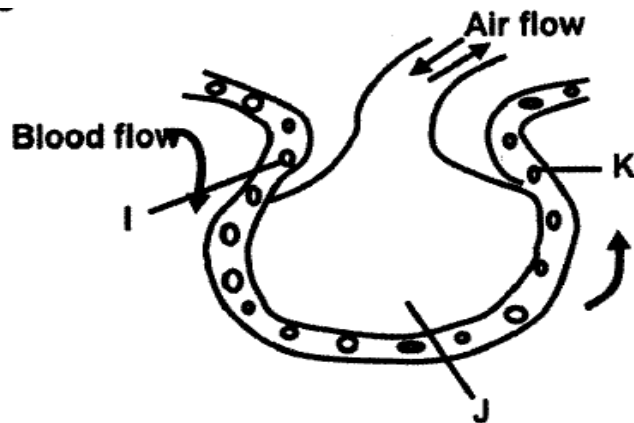

What are the concentrations of carbon dioxide at I, J and K

QUESTION EIGHT

The diagram below shows structures related with breathing and gaseous exchange in the human body.

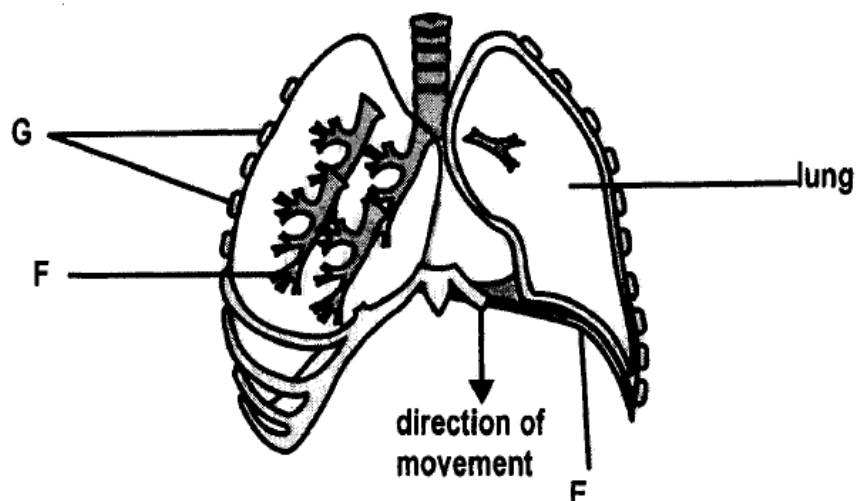

- Identify the parts labelled E and F.
- What is the function of the parts labelled G.
- If the part marked E moved in the direction of the arrow, explain what would happen to: (i). lungs (ii). Parts marked G
- Describe the term lung capacity.
- Explain the effect of cigarette smoking on the respiratory system.

## 2.2 HEALTH

### 2.2.1 Sexually transmitted infections

#### QUESTION NINE

- What do the letters STI stand for?
- Give examples of common sexually transmitted infections (STI)
- Describe the causes of the sexually transmitted diseases you in (b) above.
- Discuss the symptoms of: (i) HIV and AIDS (II) Gonorrhoea.
- A grade nine girl was diagnose with Syphilis and HIV and AIDS. How will the girl advise others boys and girls in class on the prevention of sexually transmitted infection (STIs)?
- Explain how blood to blood contact transmission of STIs may occur.

## 2.3 THE ENVIRONMENT

### 2.3.1 Cycles in the biosphere.

#### QUESTION TEN

- Define the term biosphere.
- With the help of diagrams, describe what oxygen and carbon cycle are.
- What factors affect oxygen and carbon cycles?

#### QUESTION ELEVEN

The diagram below shows the carbon cycle.

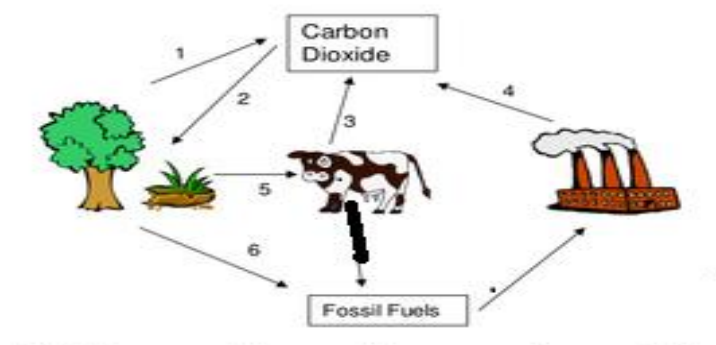

- a. What processes are represented by the following numbers: 1, 2, 3, 4, and 6.
- b. Explain the importance of process 1 and 2.

#### QUESTION TWELVE

Study the diagram of the nitrogen cycle below and answer the questions that follow

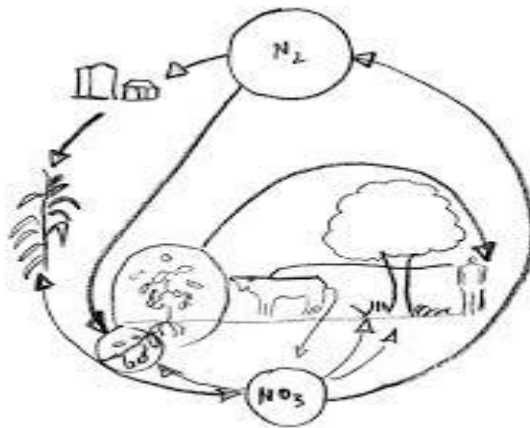

- a. By what process does nitrogen move from the air in to the soil?
- b. What name is given to plants which convert nitrogen from the air into the plant?
- c. Chilufya discovered that the soil in his garden lacked nitrogen. How can he add more nitrogen to the soil to make the soil more fertile?

#### 2.3.2 Water management

#### QUESTION THIRTEEN

- a. Give any four importance of water management.
- b. Why is water management necessary?
- c. Discuss the effective water management systems.
- d. Design a flow chart to show the process of water purification.

#### QUESTION FOURTEEN

- a. Give the correct term for each description given below:
  - i. The production of electricity using water
  - ii. The device used to turn energy from running water in hydro electricity
  - iii. The production of electricity using steam from hot water reservoirs under the earth.

#### QUESTION FIFTEEN

Study the flow chart below and answer the questions that follow:

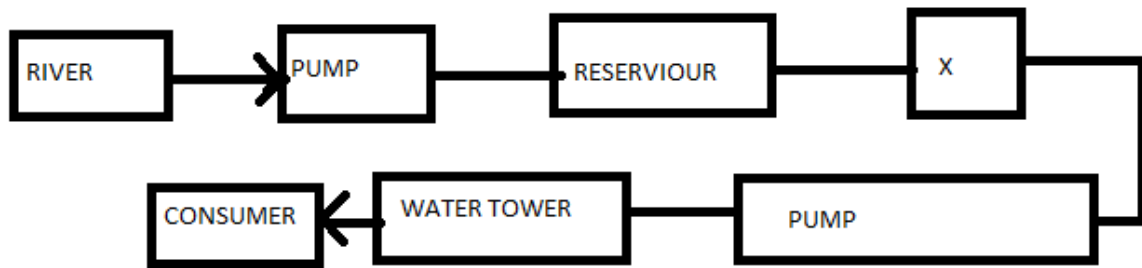

- Name the process that this flow chart represents.
- Identify the part labelled X.
- Why is effective water management important?
- List any three sources of water.
- Give any method used to purify water on a small scale.
- Name any four examples of water-borne diseases.

### 2.3.3 Conservation of animals and plants

#### QUESTION SIXTEEN

- Describe what domesticated animals and plants are.
- Define the following terms: (i). wild life (ii) extinction (iii) conservation
- Give examples of domestic animals and plants.
- Kantanga was a small scale farmer. He came to discover that his animals and plants were not as good (quality) as those for his fellow farmers in the region. Suggest ways of improving domestic breeds in animals and plants Kantanga can use.
- Give examples of animals and plants which are threatened by extinction.
- Explain the importance of protecting endangered animals and plants.
- Kapwenge discovered that some animals and plants were depleting in his area. What advice would you give Kapwenge on how he can protect the animals and plants threatened with extinction in his area?

### 2.3.4 Photosynthesis.

#### QUESTION SEVENTEEN.

- Define the term photosynthesis?
- Give the conditions necessary for photosynthesis?
- Identify the products of the process of photosynthesis?
- Distinguish between photosynthesis and respiration?

QUESTION EIGHTEEN

Study the diagram below and answer the questions that follow.

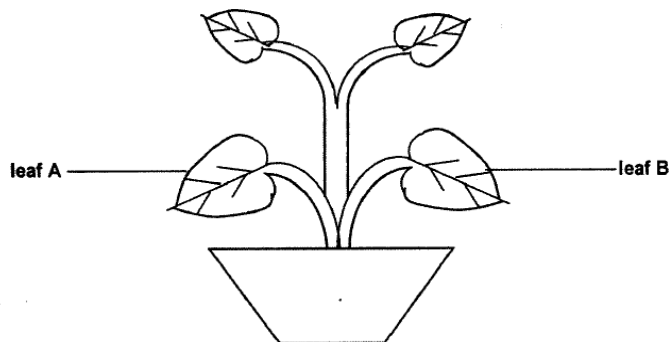

- What was the essence of putting the plant in dark for 48 hours?
- Other than starch, give one use of the products of photosynthesis within the plants.
- Explain how increase in temperature leads to increased transpiration
- Describe the role of plants in maintaining the composition of air in the atmosphere.
- Mulenga and Chanda were found sleeping in a dark room full of plants with windows closed s. Explain why that is not advisable.

**2.3.5. Transpiration**

- Define the term transpiration.
- Investigate the factors that affect the rate of transpiration
- Explain the importance of transpiration in plants.
- Discuss ways through which plants reduce the rate of transpiration.
- Study the diagram below showing the apparatus arranged to demonstrate that water is given out during transpiration.

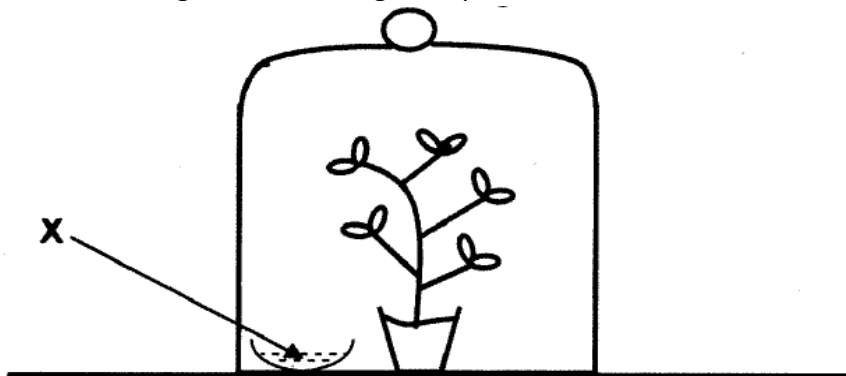

- After some minutes, substance X turned from white to blue. What could substance X be?
- Apart from substance X, give another substance that you can use to test for water in the above experiment.
- Suggest the source of water in the bell jar.
- Draw the relationship between transpiration and photosynthesis.

f. Study the diagram below and answer the questions that follow.

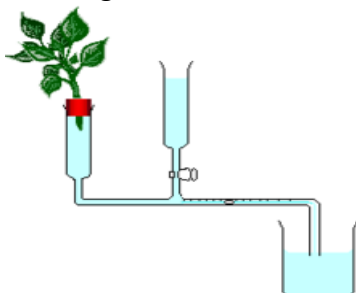

- i. Identify the instrument shown above?
- ii. Give the name of the process measured by the instrument above?
- iii. How is the rate of the process measured by the instrument above estimated?
- iv. Basing on the above experiment, write one limitation of the above instrument?
- v. Discuss precautions to be taken when carrying out the above experiment?

## 2.5.0. MATERIALS AND ENERGY

### 2.5.1. Chemical reactions.

#### QUESTION NINETEEN

- a. Describe what chemical reaction is.
- b. With well elaborate examples, describe the following chemical reactions:  
(i). Synthesis (ii). Decomposition (iii). Single replacement (iv). Double replacement
- c. Distinguish between endothermic and exothermic reactions.
- d. State the law of conservation.

### 2.5.2 LIGHT AND ITS NATURE

#### 2.5.3 Reflection and refraction of light

#### QUESTION TWENTY

- a. Define the following terms  
(i). Reflection (ii) ray of light (iii) normal (iv) reflected ray (v) incident ray.
- b. State the law of reflection
- c. The angle between the refracted ray and the normal is called .....
- d. The angle between the incident ray and the normal is called .....
- e. What do we call the ray of light after refraction?

QUESTION TWENTY ONE

Study the diagram below and answer the questions that follow.

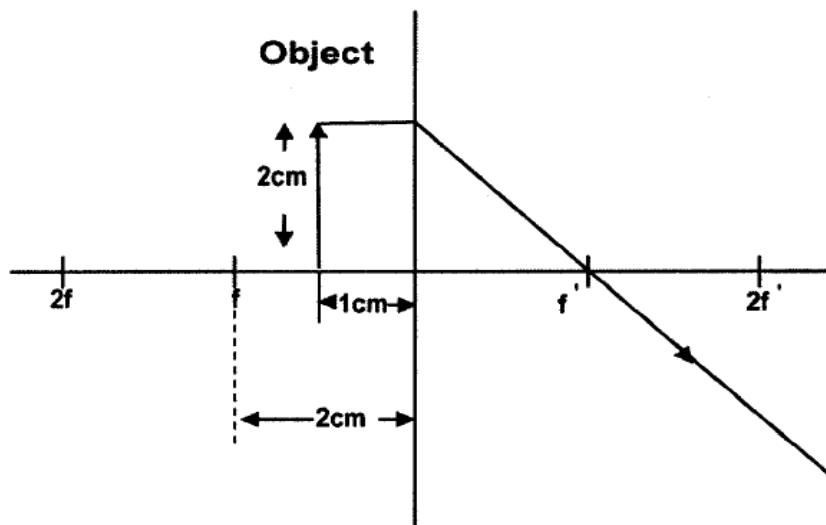

- What type of lens is being used above?
- Complete the ray diagram above.
- Measure the size of the image formed
- Calculate the magnification of the image formed.
- Give one characteristic of the image formed if the object is placed between  $2F$  and  $F$ .

QUESTION TWENTY TWO

Study the diagram showing an experiment on light.

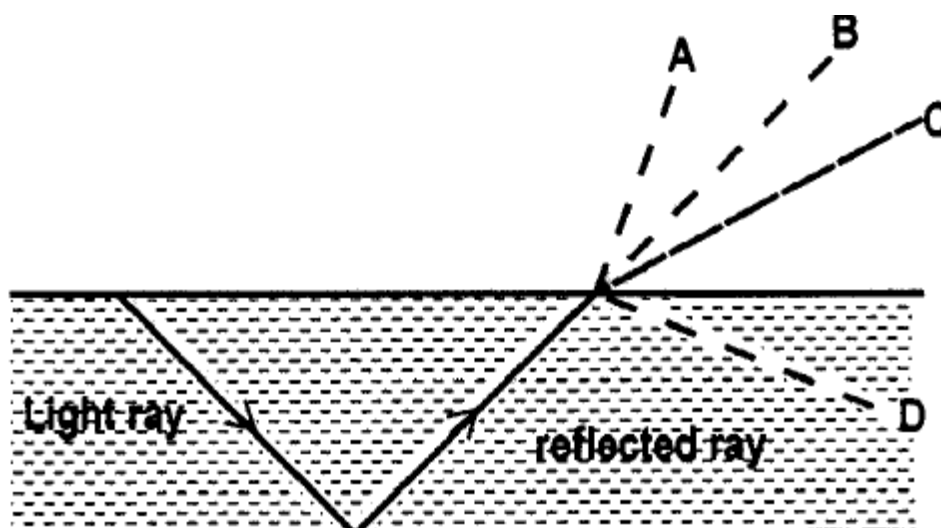

Identify and circle the correct point at which the reflected ray will emerge out of the water.

QUESTION TWENTY

Study the diagram below which shows the effect of directing a ray of light on to a plane mirror, then answer the questions that follow.

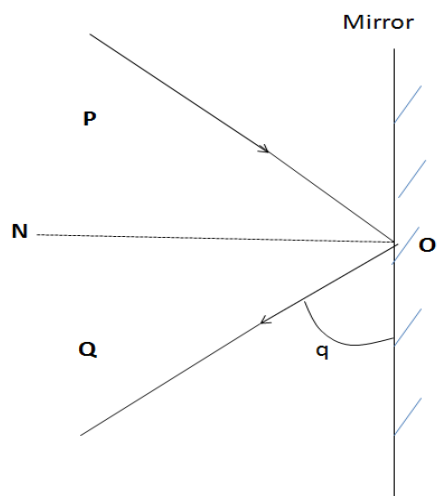

- Name the bending of light exhibited by the mirror.
- Identify the rays PO and OQ
- Given that angle  $PON = 40^\circ$ , find angle  $q$  (show all your working)
- Suggest one instrument that uses reflection of light in everyday life.

### QUESTION TWENTY THREE

Study the diagram below showing an experiment on light.

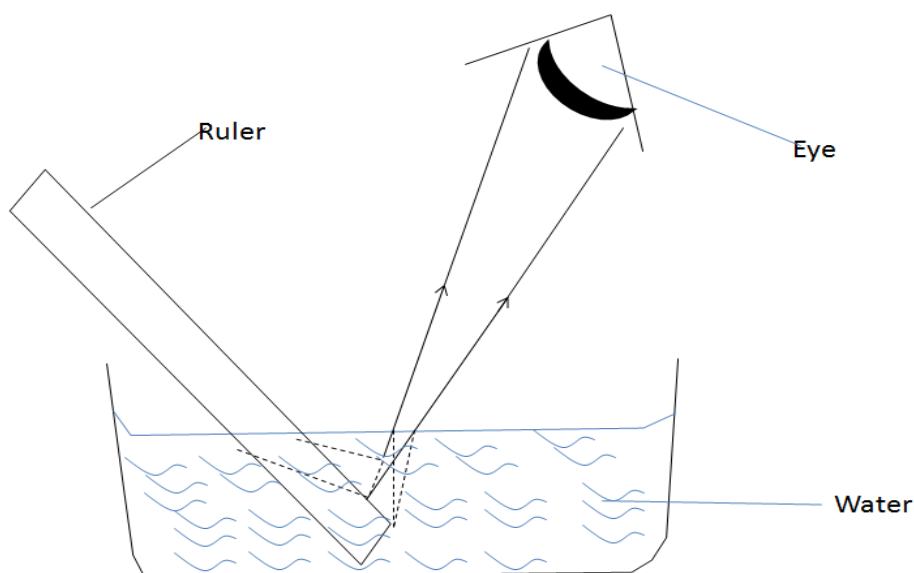

- Name the process that occurs to light as it moves from water to air.

- b. List down two effects of the process you mentioned that you can observe in the diagram.
- c. When the light was passing through the above arrangement, a faint band of different colours was observed on a white wall nearby, name the process that caused this observation.
- d. Suggest what you would use in order to get a bright band of colours observed in (c) above.
- e. Describe the way by which you would reverse the band of colours to obtain white light using what you have mentioned in (d) above.

#### QUESTION TWENTY FOUR

- a. With the help of a diagram, show the image formed when an object is placed between F and 2F of a converging lens.
- b. Describe how rain bows are formed.
- c. Musonda always wondered as to why the sky at sunsets and sun rise appeared red. What scientific explanation can you give to him?
- d. Describe the effects of colour filters on light rays.

### 2.5.4 ELECTRIC CURRENT AND VOLTAGE IN CIRCUIT

#### QUESTION TWENTY FIVE

- a. Define the following term (i). Current (ii). Voltage (iii). Circuit
- b. Distinguish between electric current and voltage.
- c. Using the values from the table below, plot voltage against current graph.

Voltage	4	6	8	10	12	14	16
Current	2	3	4	5	6	7	8

- (i) State the ohms law.
- (ii). From the graph you have plotted above, what is the relationship between voltage and current?
- (iii). If the current reading is 2.5 Amperes, what would be the reading of the voltage?
- (iv). Calculate the resistance of the appliance used in the experiment to obtain the results in the table.

#### QUESTION TWENTY FOUR

Study the diagram below showing an experiment to investigate the effect of passing an electric current through pure water.

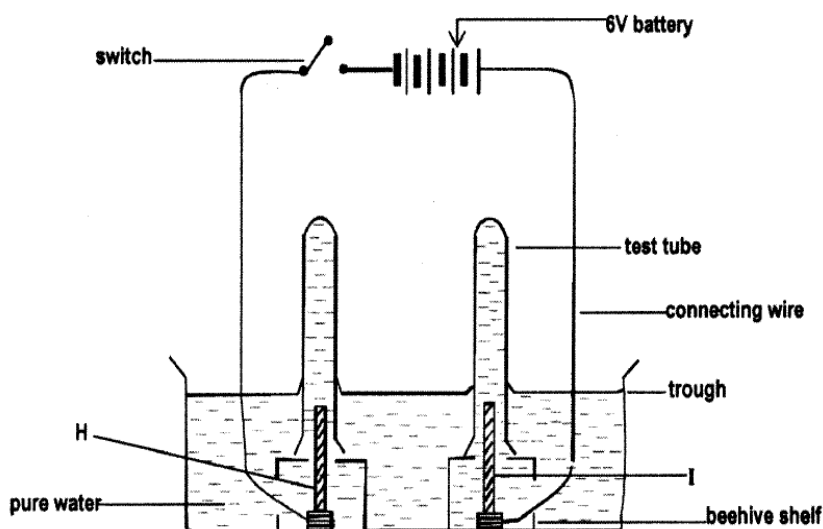

- Identify the electrodes H and I.
- Give a reason as to why the acid is added to the pure water.
- What is the identity test for the gas produced at the electrode I?
- Explain how you would collect the gases from the above experiments.
- Write the word equation to show what happens to water I at the end of the reaction.

QUESTION TWENTY SIX

- Graph I shows the results of varying the voltage and current passing through bulb P in the circuit diagram II

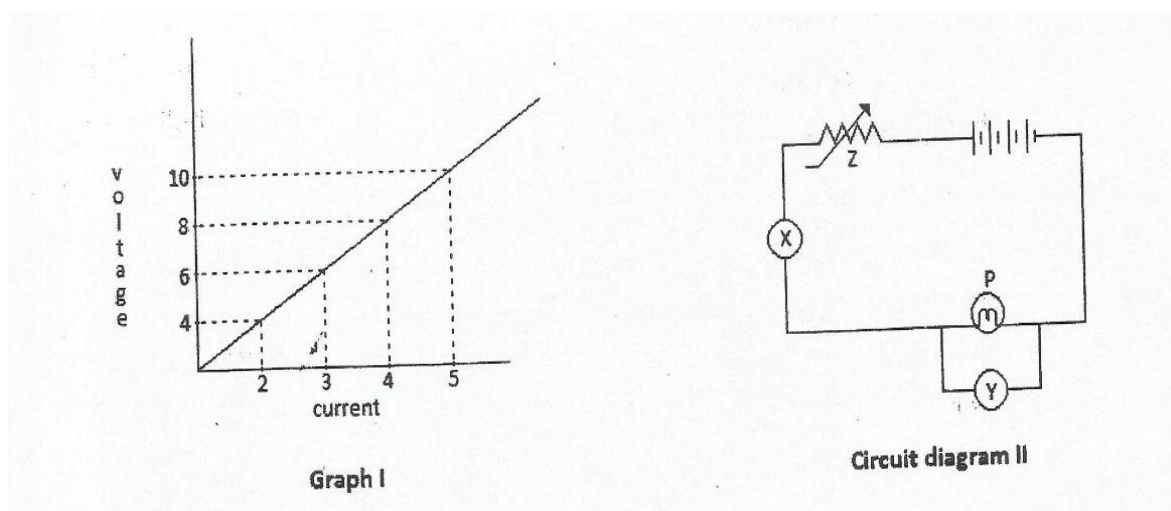

- What letters X, Y, Z represent the instrument used for varying resistance in order to change voltage (p.d.) and current in the circuit? [1]
- What happens to the value of instrument Y if the value of Z is decreased? [1]

- c. From the graph, what is the relationship between voltage and current? [1]
- d. If the current reading is 2.5 amperes, what would be the reading of the voltage? [1]
- e. If the voltage in another circuit is 6V and the resistance is 4 ohms, calculate its power. Show your working. [2]

### QUESTION TWENTY SEVEN

Study the circuit diagram below.

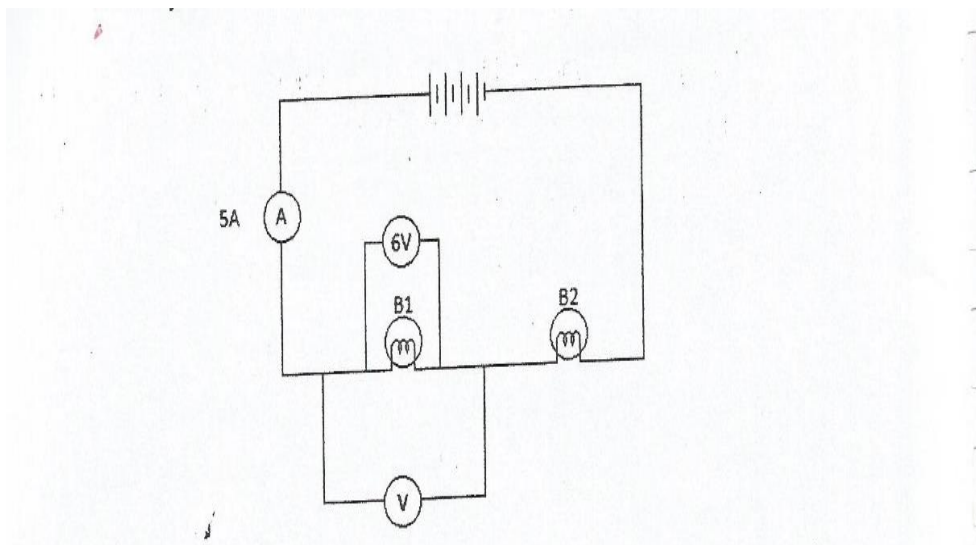

- a. How are the cells arranged?
- b. If each cell is 2.5V, what is the total voltage across the circuit?
- c. Calculate
  - i. Total resistance across B<sub>1</sub> and B<sub>2</sub>.
  - ii. Resistance across B<sub>2</sub>
- d. What is the total power in both bulbs (show yow working)

### QUESTION TWENTY EIGHT

The circuit diagram shows instrument that can be used to investigate the relationship between current and the voltage.

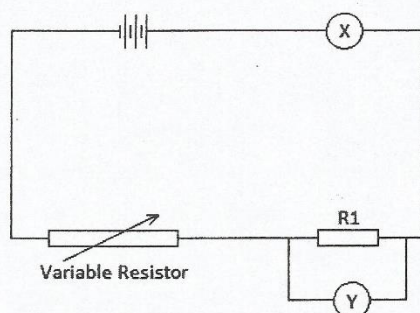

- a. What is the name of instrument X.
- b. What does instrument Y measure?
- c. In one such experiment, a pupil got the result and plotted a graph as show below.

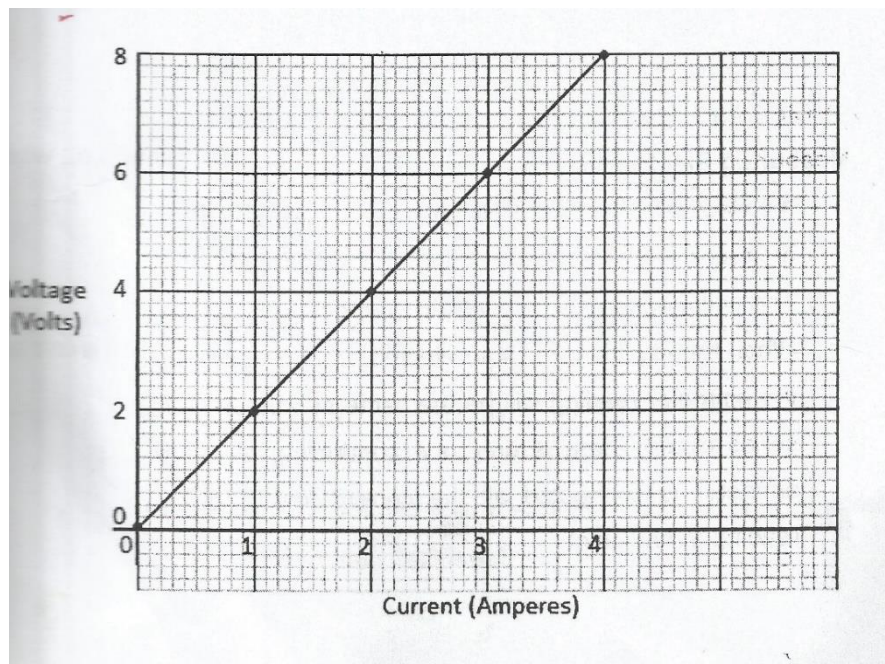

- i. What conclusion can be drawn from the results above? [1]
- ii. What is the voltage when the current is 2.5 Amperes? [1]
- iii. Calculate the power used by resistor ( $R_1$ ) when the current is 2.5 Amperes.
- d. Calculate the resistance of  $R_1$  [1]

## 2.5.5 PRESSURE

### QUESTION TWENTY NINE

- a. What is pressure?
- b. Write the formula for pressure.
- c. Identify factors that affect pressure in gases.
- d. Musonda was asked to cut an orange in two halves. He was provided with two knives, one sharp edged and the other blunt.
  - (i). With which knife will he find it easier to cut an orange?
  - (ii). Give a reason for your answer in (i) above.

### QUESTION TWENTY NINE

Study the diagram below and answer the questions that follow.

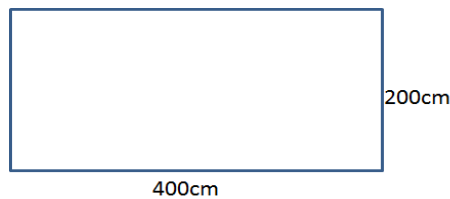

- Calculate the area of the block.
- If the block weighs 80N, find the pressure exerted on the surface.
- Calculate the force that an object would exert on a surface if its contact area is  $2.0\text{m}^2$  and pressure it exerts is  $400\text{N/m}^2$ .

## 2.5.6 ENERGY AND ITS CONSERVATION

### QUESTION THIRTY

- Explain what energy is?
- Identify different forms of energy.
- Describe how different forms of energy can be changed.
- Write the effects of energy production on the environment.
- Predict ways of conserving energy.

### QUESTION THIRTY ONE

Study the cycle below and answer the questions that follow:

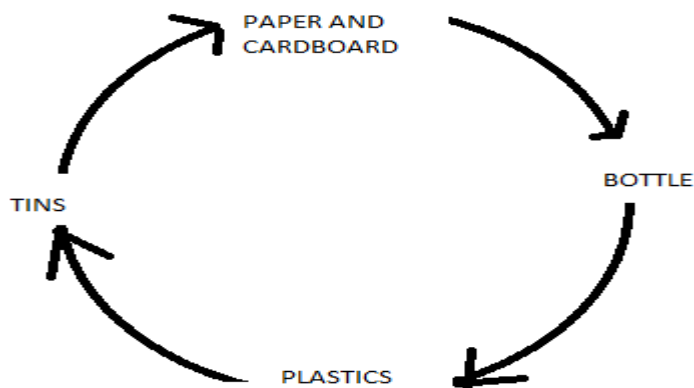

- Name the cycle shown above.
- What do you understand by the term recycling?
- One of the three Rs of conservation is 'reduce'. Explain what reduce mean and how you can help towards reducing.
- Give examples of products that can be recycled.
- Describe five ways in which we can reuse in everyday life.

### 2.5.7 COMMUNICATION

#### QUESTION THIRTY TWO

- Identify ways of ways of sending and receiving information.
- Describe the advantages and disadvantages of the different ways of sending messages.
- Study the diagram below and answer the questions that follow.

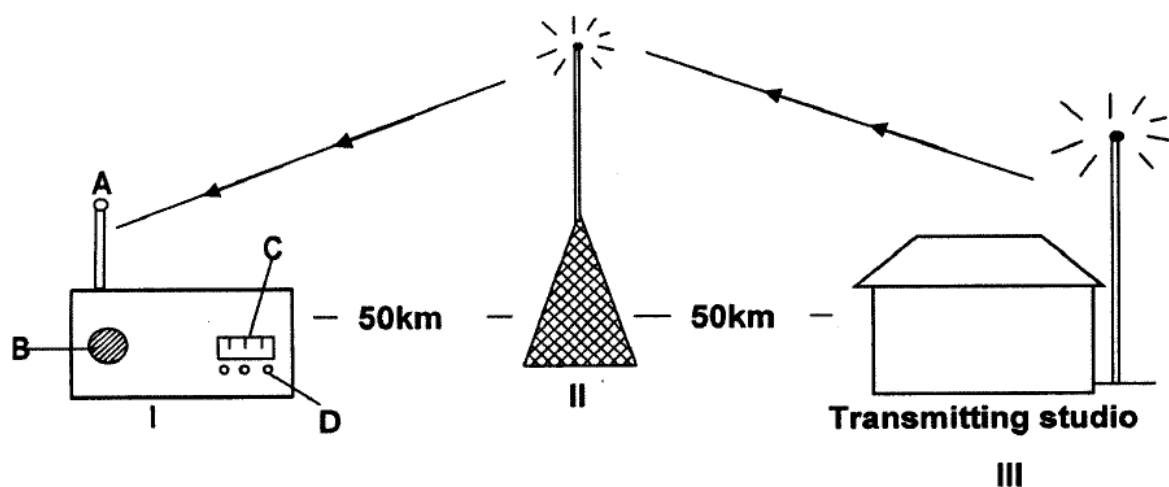

- In what form do the radio signals travel from part II to I?
- Describe the function of A from the above diagram.
- Identify the part labelled II.
- Explain the effect on the radio if part II was removed.  
What is the function of the tracking disc?

Explain how Zambia has benefitted from the installation of a tracking disc at Mwembeshi Earth Station.

### 2.5.8 DIGITAL AND ANALOGUE TRANSMISSION

#### QUESTION THIRTY THREE

- Define the term transmission
- What do you understand by analogue transmission?
- Give the advantages of using digital transmission over analogue transmission.

QUESTION THIRTY FOUR

Study the drawing illustrating radio transmission and reception with a town within Zambia.

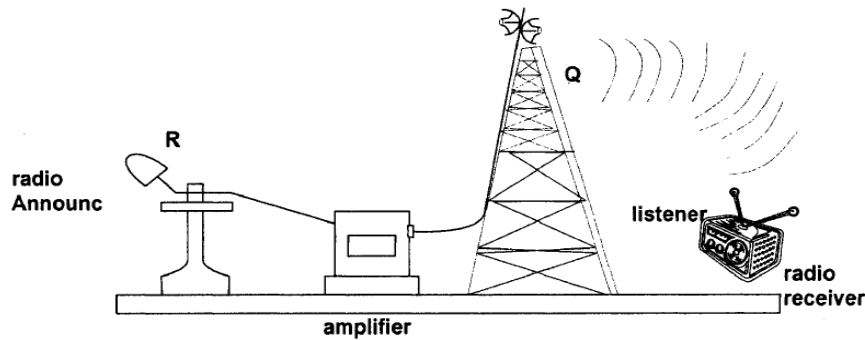

- Identify devices R and Q
- State the functions of part R and amplifier.
- Suggest a device that can be included in the transmission of radio signal from this town to another town (i). Within Zambia (ii). In Russia.

QUESTION THIRTY FIVE

Study the diagram below and answer the questions that follow.



- Identify the part labelled X.
- What would be the effect of removing part X from the above machine?
- Give the functions of the following (i). fine tune (ii). Loud speaker (iii). Picture tube (iv). Video speaker.
- Discuss the role played by a satellite earth station in television communication.
- Distinguish between live broadcasting and recorded broadcasting.

## SUGGESTED ANSWERS

### GRADE EIGHT (8)

#### 1.1 THE HUMAN BODY

##### QUESTION ONE

- i. System    ii. Organ    iii. Reproduction    iv. 2-3-1-4    v. 10 weeks

##### QUESTION TWO

- i. 2 – prostate gland, 3- Cowper’s gland, 6 – bladder, 8 – sperm duct, 9 – penis, 10 – epididymis, 11 – testis.
- ii. 2 (prostate gland): it adds alkaline secretion to the fluid which is essential to neutralize the acidic secretions present in the vagina.  
3 (Cowper’s gland): adds clear mucus to the fluid which acts as a lubricant.  
6 (bladder): stores urine.  
8 (sperm duct/ vas deferens: is a tube that conducts/ transports sperms from the epididymis to the penis.  
9 (penis) it deposits sperms into the vagina during sexual intercourse or copulation.  
10 (epididymis) stores the sperms. The sperms mature in this structure before they enter into the vas deferens/ sperm duct.  
11 (testis): - produces sex hormone called testosterone which bring about secondary sexual development in males. – it also produces male sex cells (sperms)
- iii. Vas deferens.    iv. Sperms    v. fertilization will take place to form a zygote.

##### QUESTION THREE

- i. a. Uterus    b. Fallopian tube/ oviduct    c. Ovary    e. cervix    f. vagina
- ii. a. Uterus/ womb: this is the organ where the embryo develops into a foetus.  
b. Fallopian tube/ oviduct: this is where fertilization takes place. It is also a passage for the ovum from the ovary to the uterus.  
c. Ovary: it produces the egg or ova. The ovum is the female sex cell.  
e. Cervix: also supplies the vagina with mucus which a fluid which lubricates the vagina.
- iii. Ovary
- iv. Fallopian tube/ oviduct.
- v. Fertilization is the fusion of the sperm with the ovum in the oviduct. During sexual intercourse, thousands of sperms are deposited into the vagina. Sperms

swim through the cervix into the uterus up to the oviduct. Contact between sperm and ovum makes sperms to release an enzyme which break through the wall of the ovum. A small path is created that allows the head of the sperm to enter the ovum. This allows the nucleus of the sperm to fuse with the nucleus of the ovum and they together form a zygote.

- vi. Uterus/ Or in the part labelled 'a'.

#### QUESTION FOUR

- a. A: placenta B: umbilical cord C: amnion sac/ bag D: amniotic fluid E: cervix F: Urethra
- b. A: placenta: it supplies food nutrients to the developing embryo for health growth and development. It also supplies oxygen to the embryo. The placenta also removes the waste products from the foetus. It also acts as a filter by preventing the entry of harmful micro-organisms from the mother into the foetus.  
B: umbilical cord: it holds and connects the foetus to the placenta. The umbilical cord has a vein and an artery. The umbilical vein transports food nutrients and oxygen in to the foetus while the umbilical artery transports the waste products and carbon dioxide from the foetus.  
C: amnion sac: is a sac/ bag where an embryo develops. The amnion bag also protects the foetus from injury.  
D: amniotic fluid: provides physical support to the foetus in the womb and allows the foetus to float on it. It also prevents dehydration of the foetus. It also protects the foetus against external shock (acts as a shock absorber). It is also a lubricant where the foetus moves or turns about inside the uterus.  
E: cervix: also supplies the vagina with mucus which a fluid which lubricates the vagina.  
F: urethra: is a passage for urine.
- c. Gestation period is the time between fertilization (conception) through the stages of embryo development to a fully formed baby until birth.
- d. The process of labour: when the foetus is ready to be born, the uterus and the muscle begin series of contractions. The contractions of the uterus and abdomen becomes strong and continuous. Then the cervix relaxes and gradually enlarges. This cause the amnion sac to break and releases the amniotic fluid. Next, the wall of the uterus contracts strongly pushing the baby through the cervix and the vagina with the head first to prevent the baby from drowning. The baby begins to cry immediately it comes in to contact with the cooler air outside the uterus. Then the umbilical cord is tied tightly in to two places and cut in between the two places to prevent bleeding from both the mother and the baby. Shortly afterwards the uterus contracts again and the placenta and the umbilical cord are expelled as after birth.
- e. The foetus turns facing the head downwards (just above the cervix)

- f. i. Using contraceptive pill. Contraceptive pills contain chemicals that prevent the ovaries from releasing ova.
- ii. Using the condom/ sheath: it is worn by male or female to trap and prevent sperms from getting in to the vagina.
- iii. Using rhythm method: this involves avoiding intercourse at times in the menstrual cycle when the ova are released.
- iv. Sterilization: this involves cutting and tying of the fallopian tube in the woman to prevent the ova from entering the womb.
- g. Before birth: i. visiting the antenatal clinic to monitor the growth of the foetus  
ii. Abstaining from harmful drugs by a pregnant woman to avoid miscarriages.  
After birth: i. Breastfeeding the baby.  
ii. Taking the baby to the under- five clinic to monitor the growth of the baby.
- h. February – from 10<sup>th</sup> to 23<sup>rd</sup> . 9 months from fertilization.
- i. It was earlier. The baby was born in the 8<sup>th</sup> month. The normal birth was supposed to be in January.

*QUESTION FIVE.*

- a. Puberty/adolescence is the stage in the development when one reaches sexual maturity and becomes capable of reproducing. It is when reproductive organs become matured.
- b. It is important because it enables reproductive organs become matured.
- c. Sex hormones are steroid hormones that are produced by ovaries and testes which bring about secondary sex characteristic.
- d. Female- ovary, male – testes.
- e. Oestrogen is produced by ovaries. It stimulates the development of secondary sex characteristics which include: development of the breasts, growth of hair in pubic areas followed by growth of hair in the armpit, enlargement of hips an beginning of ovulation and menstruation.  
Testosterone is produce in the testes. It stimulates the development of secondary sex characteristics in males. These include the increase in size of the testicles, growth of hair in pubic areas, hair in the armpit, deepening of the voice and the broadening of the chest.

**1.2 HEALTH.**

*QUESTION ONE*

- a. A nutrient is a substance found in food which provides the body with nourishment necessary for growth.
- b. Carbohydrates, fats/lipids, proteins, water, mineral salts, vitamins, roughage/ dietary fibre. To remember the seven classes of nutrients use this: CALIPROWAMIVORA
- c. Carbohydrates release energy which is used for different processes such as locomotion, growth, pumping blood, etc. proteins form protoplasm of the cells. They

also make new cells for the repair of damaged tissue and for growth. Vitamins and mineral salts protect the body against diseases and improve the immunity of the body. Water is the main solvent in which food dissolves. Roughage reduces constipation.

- d. i. Sick people need protein to repair parts of the body tissue affected by the diseases. They also need vitamins to promote the immune system. Carbohydrates are also needed for energy.
- ii. Pregnant mother requires all the nutrients especially calcium and vitamins for development of strong bones. Iron is also important in the development of haemoglobin which carries oxygen around the body. If these nutrients are not taken by the pregnant mother, they will diffuse from her blood into the embryo's body and the mother will become anaemic and weak. Pregnant mothers also need carbohydrate which will provide energy to help carry the embryo in her womb.
- iii. lactating: requires all the seven classes of nutrients. She should feed frequently to produce enough milk.
- iv manual worker: requires a diet with a lot of energy giving foods to provide energy to carry out different activities.
- v. Elderly people: needs less carbohydrates since they are not physically active. The diet should include protein, vitamins and mineral salts.
- vi. Sedentary worker: needs less carbohydrates because they do office work, but requires a balanced diet.
- e. Refer to the table below.

Food nutrient	Sources of food nutrients	Lack of it causes
Vitamin A	Liver, egg yolk, vegetable, carrots.	Poor night vision, or night blindness, sores in eyes dry skin
Calcium/ vitamin D	Liver, fish, milk, egg-yolk	Rickets
Lipids	Butter, ground nuts, milk.	
Carbohydrates	Potatoes, maize, rice, cassava, millet	Marasmus
Roughage/ dietary fibre	Cereals, popcorns, vegetables.	Constipation
Iron	Liver, beef, egg- yolk, millet, green vegetables.	Anaemia
Vitamin C	Fresh citrus fruits	Bleeding of gums, anaemia, slow healing wounds.
Iodine	Iodised table salt, sea foods	Goitre, retarded growth
Protein	Beans, meat, fish	Kwashiorkor
Fluorine	Drinking water	Weak teeth.

*QUESTION TWO.*

- a. Child's family information, immunization program, age and mass of the child, nutritional information.
- b. Monitors the growth of the baby. Every month the woman visits the under- five clinic the weight of a child is recorded. Depending on the weight, the doctor may recommend some diet for a child.
  - ii. Provide immunization: during clinics, children are immunized against diseases such as tuberculosis, whooping cough, diphtheria, tetanus, polio and measles. All these are immunizable diseases.
  - lii provide supplements. If the doctor notices some signs of nutritional deficiency diseases in some children, they are given supplements for various nutrients that they may be lacking.
- iv. It also provides nutritional advice to mothers on what nutrients to include in their babies diet and their quantities.
- c. Graph
  - I. It increased steadily
  - II. The baby's weight was constant
  - III. The weight dropped because the baby might have become ill, had diarrhoea or had poor diet , malaria, fever, etc.
  - IV. -Type of food given other than breast milk.
    - Viruses in the air breathed in
    - Diseases such as malaria
    - Infection caused by bacteria.
- v. (a) 4.5 Kg (b). 3 months.

**1.3 THE ENVIRONMENT**

*QUESTION ONE*

- a. Pollution is the addition of harmful substances to the land.
- b.
  - i. Water pollution is the contamination of harmful substances e.g acid, oil, sewage to the water source.
  - ii. Air pollution is the release of pollutants to the air such as sulphur dioxide, smoke, oxide of nitrogen, carbon dioxide, carbon monoxide and CFCs.
  - iii. Land pollution is the contamination of harmful substances such as sewage, fertilizers, oil, acid, etc to the land.

c. Water pollution: is caused by the following: releasing untreated sewage direct to the water source. Fertilizers and pesticides from the agricultural fields are carried into the water sources. Chemicals and wastes from factories are sometimes disposed in to streams and rivers. Oil spillages are also source of water pollution.

Air pollution: sulphur dioxide and carbon monoxide release from burning fossil fuels causes air pollution. Burning of leaves and plastics also releases smoke which contaminates air. Eruption of gases like sulphur dioxide volcanoes are also a cause of air pollution.

Land pollution: is caused when garbage such as rubbish or wastes such domestic refuse, metals and plastics are disposed on the land. Oil spillages during transportation may also be a source of land pollution.

*d.(i). EFFECTS OF LAND POLLUTION*

Heaps of garbage cause poor sanitation. As a result, diseases such as typhoid, dysentery and cholera are caused because of poor sanitation. Garbage also attracts flies which carry germs, thus spreading diseases. Garbage once stayed at one place for a long time, it decomposes and begins to produce unpleasant smell. Chemicals from factories and pesticides sprayed on the land contain harmful substances that may reduce the productivity of the land.

*(ii). EFFECTS OF AIR POLLUTION.*

When gases like sulphur dioxide is released in to the atmosphere, it reacts with water molecules to form acid rain which is harmful to plants. It erodes the cuticle layer thereby preventing photosynthesis from taking place. It also erodes buildings.

Poisonous gases such as carbon monoxide once released in the environment cause difficulty in breathing. These gases may cause irritation in some of the organs of the respiratory system. This gas also leads to stunted growth in plants due to lack of fresh air which contain carbon dioxide for photosynthesis. It also causes global warming.

e . acid rain is caused by sulphur dioxide released from burning of fossil fuels. Once this gas is released into the atmosphere, it reacts with water molecules forming acid rain.

f. HOW AIR POLLUTION CAUSES GLOBAL WARMING: global warming is the gradual increase in the average temperature of the earth. It is caused when the amount of carbon dioxide and other green- house gases increase in the air. These gases prevent the escaping back into the space the heat energy from the sun. As a result, the temperature of the earth's surface and that of the atmosphere rises, making it warmer than usual, causing what is referred to as global warming or the green-house effect.

NOTE: global warming changes the climate thereby affecting agriculture.

g. Some of the ways that can be used to prevent air pollution are as follows:

Education programs should be introduced at all levels on the harmful effects of air pollution. There should be a ban of manufacturing of certain products that produce air pollution. Promotion of the use of lead free petrol engines which causes less pollution. Encourage those in management companies dealing with sulphur dioxide to consider re-using the gas in making sulphuric acid instead of releasing it to the air. People should also be encouraged to use sources of energy such as electricity, wind energy and solar energy which do not pollute the environment.

Prevention of land pollution: By encouraging manufacturing industries to recycle wastes such as plastics and metals which do not decompose (non- biodegradable substances). Stiffening of rules such as sentencing of those disposing off garbage carelessly for at least three months. Come up with programs to sensitize people on the importance of keeping the environment clean.

Prevention of water pollution: encourage the manufacturing industries to ensure they have good drainages and sewage system. Encourage people building toilets and latrines to build them at least ten metres away from wells and other water sources to avoid contamination through seepage. Discourage industries from disposing off industrial effluents/ wastes direct into water sources. Encourage farmers also to reduce the use of agricultural chemicals such as fertilizers and pesticides on farm land, since these are the chemicals carried away in to the rivers by rain water.

- h. This is the process by which a body of water acquires high concentration of nutrients from the sewage and fertilizers. These two pollutants contain phosphates and nitrates which promotes excessive growth of algae. When the algae die and decompose, high level of organic matter and decomposing organisms deplete the water of available oxygen causing the death of other organisms such as fish and other aquatic living organisms.

#### *QUESTION TWO*

- i. Trees/ woodlands.
- ii. Cutting down of trees (deforestation) and sewage discharge into the river.
- iii. Plant more trees (afforestation) and stop disposing waste product and industrial waste in to the river.
- iv. To plant new trees after cutting some trees for paper production.
- v. To control and reduce deforestation of trees. Apart from that people are supposed to be educated on the importance of having trees in the environment.
- vi. Air pollution – the truck is releasing smoke containing carbon monoxide.

#### **1.4 PLANTS AND ANIMALS**

- a. E: body tube, F: adjusting knob, G: ice piece, H: objective lens, I: stage, J: mirror.
- b. Body tube holds the eye piece and objective lenses in position and allows light from the specimen to pass to the observer.  
Adjusting knob brings the object into focus.

Ice piece contain the lens which magnify the object under observation.

Objective lens magnifies the object or specimen being examined.

Stage is the place where the specimen is placed during examination.

Mirror directs or reflects light to the object/ specimen being examined.

- c. Break the onion scaly leaf. Peel off the thin inner skin with the aid of a pair of forceps or finger nails and place it in a container. Place a drop of water on a microscope slide. Cut a small piece o onion skin and place it on a drop of water on the slide. Mount the slide on the microscope and clip it with the cover clip. If there are any bubbles, add water to side and drain it on the other side using the absorbent paper. Then observe the onion cells by slowly turning the fine adjusting knob either clock wise or anti clock wise.

**Note:** The observed image should be drawn while observing the image, and the magnification should be calculated by multiplying the magnification power on the ice piece and on the objective lens.

- d. A microscope magnify small objects which cannot be seen with the naked eyes.
- e. Microscopes are used in the cameras and film projectors.

**QUESTION TWO.**

- a. Meristems
- b. A: is from the shoot system (shoot part of a plant). B: is from the root system (root part of a plant)
- c. Cell division region: a region where cells are actively dividing.  
Cell elongation region: a region where cells absorb a lot of water in their vacuole and become bigger in size.  
Cell specialization region: a region where cells develop features to enable them carry out specific functions.
- d. B is positive geotropic whereas A is positive phototropic.

**QUESTION THREE**

- a. A: cell wall, B: cytoplasm, C: vacuole, D: nucleus.
- b. D: controls chemical reactions e.g respiration, cell division, synthesis of cells.
- c. Vacuole/ structure C
- d. Cell membrane, cytoplasm and nucleus. These three make up the protoplasm (living part of the cell).
- e. Similarities: they both contain the nucleus, cytoplasm and cell membrane.

Differences:

Plant cell	Animal cell
Presence of cell wall	No cell wall
Regular shape because of cell walls.	Irregular shape due to lack of cell walls
Presence of chloroplasts	Does not have chloroplasts
Contain a large permanent vacuole	Do not have vacuoles, however, small temporary vacuoles do occur .

*QUESTION FOUR*

- a. Light, water and gravity.
- b. Roots grow downwards because of the force of gravity.
- c. Tropisms are important because they enable shoots to grow towards light and roots to grow towards gravity or earth.
- d. Tropisms are important to farmers because farmers do not worry on how to plant their seeds. After the seeds are planted, the shoot on their own will respond to light while the root will respond to gravity.

*QUESTION FIVE*

- a. Phototropism
- b.

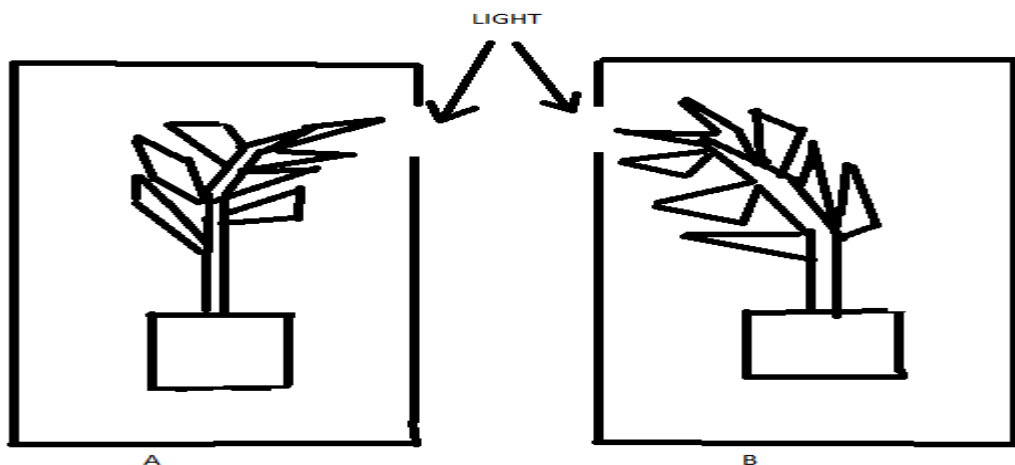

- c. Shoot responds to light by growing towards it.
- d. Negative phototropism
- e.

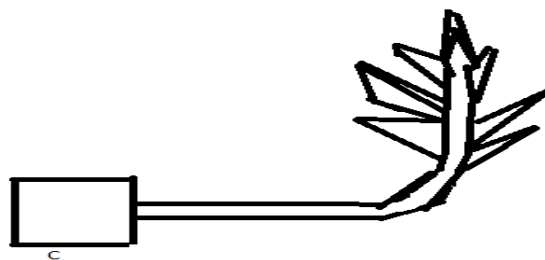

- f. The shoot grows away from the gravity.

### 1.5.0 MATERIAL AND ENERGY

- a. Recycling
- b. Recycling is a series of steps in which a used product is reprocessed, remade and sold as a new product.
- c. Reduce means using fewer resources. You can help towards reducing through the following:
  - i. By buying products made from recycled materials.
  - ii. By buying products made locally and so less energy is used for transport.
  - iii. By buying products that do not have a lot of packaging.
  - iv. Save water by turning off the tap while you brush your teeth.
  - v. Make double sided photocopies whenever possible.
- d. Examples of products that can be recycled include the following: all types of paper, cardboards, glass, metal cans, all types of plastics, oil, etc.
- e. Ways we can reuse in everyday life include the following:
  - i. By returning returnable bottles.
  - ii. Use empty bottles, jars, shoe boxes and margarine containers for storage containers.
  - iii. By turning kitchen waste into compost
  - iv. By using envelopes and paper printed on one side for making lists.
  - v. By selling clothes, appliances and furniture or donate them to needy people.

### 1.5.1 COMPOSITION OF AIR

#### QUESTION ONE

- a. Matter is anything that occupies space and has weight.
- b. Matter is composed of molecules, ions, atoms, elements, compounds, mixtures.
- c. A molecule
- d.
  - i. Oxygen element is made up of oxygen particle or atom
  - ii. Carbon element is made up of carbon particles or elements.
  - iii. Hydrogen element is made up of hydrogen particles or elements
  - iv. Aluminium element is made up of aluminium particles or elements.

Note: this applies to all elements e.g nitrogen, silicon, calcium, sodium, potassium, phosphorus, sulphur, etc.
- e. i. Cl ii. Al iii. Cu iv. H v. P

- f. i. Ca = Calcium, ii. Na = Sodium, iii. K = Potassium, iv. Be = Beryllium, v. B= Boron, vi. Si = Silicon, vii. Fe = iron, viii. Mg = magnesium.

### 1.5.2 PHYSICAL CHANGE

#### QUESTION TWO

- a. Solid, liquid and gas.
- b. Arrangement and movement.
- SOLIDS: particles are tightly packed together. Therefore, particles have great force of attraction between them. Each particle vibrates about fixed position but can not move from one position to another. This is the reason why solids have fixed shape and volume.
- LIQUIDS: particles are further apart than in solids. Particles have weak force of attraction between them. The particles move about within the liquid continuously knocking each other. They can move from one point to another but do not have a fixed shape. They take up the shape of a container.
- GASES: in gases, particles are more distantly or widely packed together. Particles have very weak forces of attraction between them. They are free to move from one point to another without any restriction. So gases have neither fixed shape nor volume.
- c. i. E-F, ii. D, iii. A-B, iv. B-C and D-E
- d. sublimation is the process by which a solid changes directly from gas to solid or from solid to gas.

### 1.5.3 MIXTURES

#### QUESTION THREE

- a. a mixture is a substance made up of two or more different substances that are not chemically combined.
- b. Air, soil, marbles, sea water, fruit salad.
- c.

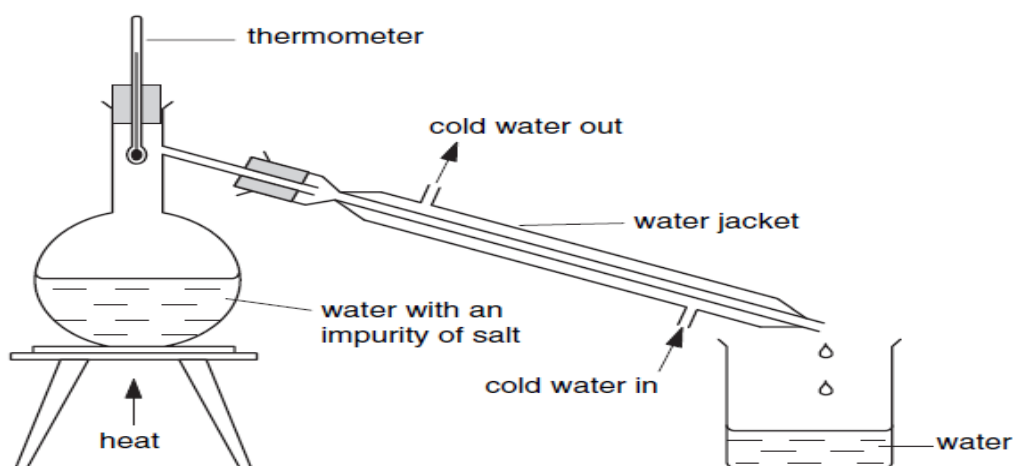

As the solution boils, the water in it evaporates as water vapour. The cold water flowing through the condenser cools the steam passing the delivery tube (water jacket). The steam condenses back to liquid which drips in to the collecting beaker. The liquid collected in the beaker is called the distillate and is pure water.

#### QUESTION FOUR

- A** is a separating funnel and **B** is a conical flask
- Floatation
- Oil and water are mixed and shaken well and pour in the separating funnel. The mixture is allowed to settle for about five minutes. Two layers are formed, that is, a layer of water and upper layer of liquid oil. The two layers are formed because liquid oil and water are immiscible. Then a tap on the separating funnel is turned on draining out the water carefully until the last drop of water comes out leaving the oil in the funnel. The oil is then poured out using the mouth a funnel in the beaker.
- Simple distillation
  - Fractional distillation
  - Magnetism.

#### QUESTION FIVE

- Fractional distillation
- To completely condense steam to liquid.
- Used to make spirits (whisky)  
-Used to separate crude oil in to different components.  
Air is liquefied then distilled to collect pure oxygen.
- The thermometer is used to measure the temperature of ethanol vapour. It increases the surface area for condensation to allow efficient separation of the component in the mixture.

- e. i. It has different boiling points. ii. The two liquids are immiscible.

#### QUESTION SIX

- a. Floatation  
b. i. Insoluble      ii. Different densities  
c. By adding frothing agents.  
d. Magnetisation.

#### QUESTION SEVEN

- a. The mixture is dissolved in the solvent (water). Sand does not dissolve and so it is filtered off using a filter paper. Then salt dissolves in water. Next, salt is recovered by slow evaporation of the solvent by using water bath. Crystals of salts are formed on the evaporation dish. The diagram below summarises the whole process.

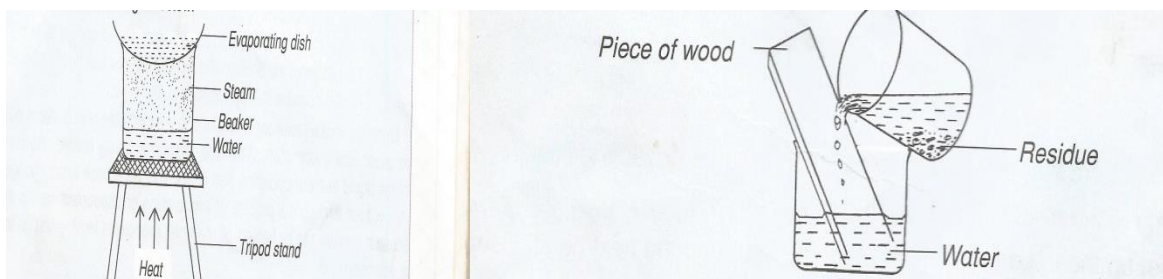

### 1.5.4 MASS AND WEIGHT

#### QUESTION EIGHT

- a. Mass is the quantity of matter contained in a substance. Weight is the pull of gravity on a mass of a body or object.  
b. Mass = Kg or g      weight = N/Kg  
c. Mass is the quantity of matter in a substance while weight is the pull of gravity on a mass of body or object.

#### QUESTION NINE

- a. i. 0.03Kg   ii. 0.06Kg   iii. 0.2Kg   iv. 2Kg   v. 5000Kg  
b. 200N      c. 0.8N      d. It depends on the shape of the earth. It's rotation.

#### QUESTION TEN

- a. Masses = 500g  
b. Spring balance  
c. 5.0N

- d. Spring balance

### 1.5.5 DENSITY

#### QUESTION ELEVEN

- a. Density is mass per unit volume  
b.  $\text{g/cm}^3$  or  $\text{Kg/m}^3$   
c.  $\text{Mg/D cm}^3$   
d.  $\text{DVg}$   
e.  $\text{M/Vg/cm}^3$

#### QUESTION TWELVE

- a.  $V = 750.0\text{cm}^3$  b.  $V = 900.0\text{ cm}^3$  c.  $V_2 - V_1, 900.0\text{ cm}^3 - 750.0\text{cm}^3 = 150.0\text{ cm}^3$ .  
d.  $D = M/V = 300.0\text{g}/150.0\text{cm}^3 = 2.0\text{g/cm}^3$

#### QUESTION THIRTEEN

- a. 150.0g  
b.  $V_2 - V_1 = 70.0\text{cm}^3 - 50.0\text{cm}^3 = 20.0\text{cm}^3$   
c.  $D = M/V = 150.0\text{g}/20.0\text{cm}^3 = 7.5\text{g/cm}^3$   
d. Calculate the volume first:  $2.0\text{ cm} \times 35.0\text{cm}^3 = 70.0\text{cm}^3$ .  
Then  $D = M/V$ ,  $D = 280.0\text{g}/70.0\text{cm}^3$  ,  $D = 4.0\text{g/cm}^3$

#### QUESTION FOURTEEN

- a. Salt water  
b. Salt water is denser than fresh water.  
c. They are hollow and displaces an amount of water whose mass is equal to the mass of the ship.  
d. Plimsoll line shows the level at which the loaded ship can be allowed to float in different waters.

#### QUESTION FIFTEEN

- a.  $D = M/V$  ,  $40.0\text{g}/80.0\text{cm}^3$  ,  $0.5\text{g/cm}^3$   
b. Measuring cylinder  
c. Density should be calculated from the graph.  
Liquid P =  $D = M/V$ ,  $10.0\text{g}/10.0\text{cm}^3$ ,  $1.0\text{g/cm}^3$   
Liquid Q =  $D = M/V$ ,  $10.0\text{g}/5.0\text{cm}^3$ ,  $2.0\text{g/cm}^3$   
P would float on Q.

### 1.5.6 HEAT TRANSFER

#### QUESTION SIXTEEN

- a. Conduction, radiation and conduction.
- b. Vibration
- c. Poor conductor of heat.
- d. Convection
- e. Rise up; force downwards
- f. Hot air rises because its density becomes less
- g. Land and sea breeze, chimney, car radiator.

#### QUESTION SEVENTEEN

- a. Cork stopper, B: inner silvered glass wall, C: vacuum, D: Sealed tip.
- b. Glass is a poor conductor of heat.
- c. It radiates or reflects heat back into the liquid to keep it hot. Or reflects heat towards the outer case to keep the liquid cold for long time.
- d. Vacuum = C, and cork stopper = A.
- e. Cork support
- f. A: reduces heat loss by convection and conduction  
D: is a point where gases or air was sucked.
- g. It is used to keep hot liquids hot and cold liquids cold for a long time.

#### QUESTION EIGHTEEN

- a. N
- b. It has higher temperature because it loses less heat.
- c. To prevent heat loss from the liquid.
- d. Radiation
- e. Polished white or silver material loses less heat than black materials.
- f. It reflects heat away and makes the inside of the house cool.

#### QUESTION NINETEEN

- a. Yes
- b. Because it has not expanded.
- c. Handles are made of wood because they are poor conductors of heat.

### 1.5.7 COMPOSITION OF AIR

#### QUESTION TWENTY

- a. Air is a mixture of gases.
- b. Nitrogen, oxygen, carbon dioxide, inert gases and water vapour.
- c. Nitrogen = 78%, oxygen = 21,8%, carbon dioxide = 0.03%, water vapour = 0.5-4.0%, and inert gases = 1.0%.
- d. Oxygen = it is a gas, colourless, odourless, It is slightly soluble in cold water, It is tasteless gas, It is denser than air.  
Carbon dioxide = is colourless, does not support burning, Is denser than air, It Dissolves in water to make carbonic acid, slightly soluble in water.  
Nitrogen: it is colourless and odourless, less denser than air, slightly soluble in water, under normal condition, nitrogen is a very inert gas.

*QUESTION TWENTY ONE*

- a. Nitrogen
- b. 20.8% = Oxygen
- c. Carbon dioxide (part of the body is used in the body for respiration)
- d. Air sac/ alveolus

## **GRADE NINE (9)**

### **2.0 THE HUMAN BODY**

#### **2.1.1 CIRCULATORY SYSTEM**

*QUESTION ONE*

- a. Circulatory system is the system that is responsible for transporting materials to and from all parts of the body.
- b. Heart, arteries, veins, capillaries, blood.
- c.
  - i. The heart is an organ responsible for pumping blood throughout the body.
  - ii. Arteries: are blood vessels that carry blood away from the heart. All of them carry oxygenated blood except the pulmonary artery.
  - iii. Veins: are blood vessels that carry blood towards the heart. All of them carry deoxygenated blood except the pulmonary vein.
  - iv. Capillaries: are thin-walled vessels that link arteries with veins. They transport blood from the arteries to the tissue and back to the veins.
  - v. Blood: it carries nutrients, water, oxygen, hormones, waste products and other important things to and from the cells.
- d. Blood consists of red blood cells, white blood cells, platelets suspended in plasma. Plasma is the liquid part of blood.
  - i. Red blood cells: are bi-concave disc- shaped cells. Contain haemoglobin which enable red blood cells to carry oxygen around the body.
  - ii. White blood cells: attack and destroy bacteria and other disease causing germs. The engulfing of bacteria by white blood cells is called phagocytosis.
  - iii. Blood platelets: are also called thrombocytes. Platelets are clots blood on wounds to prevent excess bleeding and harmful germs from entering the body.

e . Veins, capillaries, arteries.

Arteries: are large, muscular tubular, thick-walled blood vessels that carry blood away from the heart. All of them carry oxygenated blood except the pulmonary artery.

Veins: are large muscular tubular thin-walled blood vessels that carry blood towards the heart. All of them carry deoxygenated blood except the pulmonary vein.

Capillaries: are thin-walled vessels that link arteries with veins. They transport blood from the arteries to the tissue and back to the veins.

#### QUESTION TWO

- a. circulatory system
- b. 1=A=Right atrium 2= Right ventricle 3= left atrium 4- left ventricle.
- c. 6=Aorta 7= superior vena cava 8= inferior vena cava 9=
- d. For it to be purified/ for oxygenation ( to receive blood)
- e. Respiration
- f. Glucose + oxygen ..... carbon dioxide + water vapour + energy

#### QUESTION THREE

- a. Circulatory system
- b. A: Right atrium B: Right ventricle C: left ventricle D: left atrium
- c. W: pulmonary artery X: Pulmonary vein Y: aorta Z: left atrium
- d. For oxygenation/ for purification (where carbon dioxide is removed and oxygen added)
- e. Y has thick muscular wall because it transports blood under high pressure while Z has thin muscular wall and has valves which prevent the back flow of blood. Y carries oxygenated blood while Z carries deoxygenated blood.
- f. Respiration
- g. Chamber C is thicker than chamber B because it pumps blood under high pressure to all parts of the body.

#### QUESTION FOUR

- a. Circulatory system
- b. A: Right atrium B: right ventricle C: left atrium D: left ventricle.
- c. It receives oxygenated blood from the lungs and drains it to the left ventricle.
- d. The heart pumps blood to all parts of the body. Is a muscle organ that pumps blood to all parts of the body.
- e. E: carries oxygenated blood which is bright red in colour.  
F: carries deoxygenated blood which is dark red in colour.
- f. Respiration
- g. Double circulation is the type of circulation that occurs in mammals in which blood passes through the heart twice before completing a full circuit of the body. Blood is pumped from the heart to the lungs and returns to the heart before being distributed to other parts of the body.

## 2.1.2 RESPIRATORY SYSTEM

### QUESTION ONE

- a. Breathing
- b. Expiration/ exhalation
- c. Carbon dioxide inspired air = 0.03%
- d. Oxygen expired air = 16.0%
- e. Lung capacity

### QUESTION TWO

- a. 1. Nasal cavity, 2: mouth, 3: larynx, 4: lung, 5: carina of trachea, 6: diaphragm, 7: pharynx, 8: trachea, 9: bronchus, 11: alveoli/ air sacs.

### QUESTION THREE

I: High, J: 50% of Carbon dioxide and 50% Oxygen, K: Low

### QUESTION FOUR

- a. E: diaphragm F: bronchioles
- b. The ribs provide physical protection to the delicate lungs. Ribs move inwards and outwards during breathing to create space for the lungs.
- c. i. Lungs are inflated  
ii. G moves upwards and outwards.
- d. Lung capacity is the amount of air that we can breathe out of our lungs after filling them completely.
- e. Effects of cigarette smoking:
  - i. Lung cancer: is the formation of tumours in the alveoli due to abnormal division of the cells. The tar in cigarette causes irritation of the lungs, causing the alveoli cells to divide abnormally.
  - 2. Bronchitis: is the inflammation of the membrane which lines the bronchiole tubes. This inflammation is caused by viral or bacterial infection. Due to smoking, the bronchioles constrict and the cilia/ hair which line the air passage can no longer move, waft mucus and pathogens from the lungs.
  - 3. Emphysema: tar and other chemicals present in tobacco causes the break down of the alveoli wall of the lungs resulting in the reduction of air sacs/ alveoli. This reduces the surface area available for gaseous exchange.
  - 4. Asthma: causes the bronchi and bronchioles to contract and become small in alveoli. This may cause the patient to find it difficult to breathe.
  - 5. Pneumonia: this is an inflammation of the lungs and alveoli. It is caused by smoking which results in accumulation of bacteria in the lungs. The accumulated bacteria cause lung infection which lead to inflation.
  - 6. Harm to unborn baby: nicotine may diffuse from the mother's blood to that of the foetus leading to increased heart beat and increased blood pressure. This may be fatal and may cause a miscarriage in pregnant women.
  - 7. Irritation of the mouth, larynx, and pharynx: hot gases and smoke particles inhaled during cigarette smoking come into contact with the tissue and mucus membrane that surround the mouth, larynx, voice box, and pharynx or throat. These areas suffer continual irritation from smoking.

## 2.2 HEALTH

a. Sexually Transmitted Infections

b. i. HIV/AIDS ii. Syphilis iii. Gonorrhoea. iv. Genital warts

c. i. causes of HIV/AIDS

The HIV attacks the immune system which is responsible for protecting the body against diseases. The HIV attacks the white blood cells particularly the lymphocytes which are responsible for producing anti-bodies and anti-toxins. This makes the person's immune system to become weak and prone to attacks by other diseases.

ii. SYPHILIS: is caused by a bacteria called *Treponema pallidum* that gets into the blood stream through the eyes, mouth, vagina, anus or broken skin.

iii. GONORRHOEA: is caused by a bacteria called *Neisseria gonorrhoea*. This bacteria is spread from an infected person to a healthy through sexual intercourse.

iv. GENITAL WARTS: a wart is a small, hard growth on the skin caused by a virus. The virus enters through a broken layer of the skin which later grows rapidly forming a wart.

d. Symptoms of HIV/AIDS

i. Persistent and unexpected fatigue, ii. Weight loss iii. Unexplained tiredness, iii. Prolonged swelling of lymph gland in the armpits, groin or neck. iv. Diarrhoea that lasts for more than a week, v. sores of the mouth, anus or genitals, vii. pneumonia, and viii. memory loss, depression, etc.

Symptoms of gonorrhoea

i. in females, a greenish- yellow vaginal discharge with a bad smell is experienced.

ii. pain or burning sensation when urinating.

iii. red or swollen vagina

iv. pain in the lower abdomen.

v. Bleeding between periods

In males, (i). a thick, white or green yellow discharge is experienced.

ii. pain or burning sensation when urinating.

iii. itching around the tip of the penis.

iv. urinating frequently.

v. painful or swollen testicles.

e. i. abstinence ii. Correct and consistence use of condoms iii. Having one faithful partner iv. Avoiding casual sex. V. education awareness., etc.

f. Coming into contact with infected blood. For example when sharing the needles or razor blades contaminated with fresh blood can result in STIs. Other causes are abrasion, cuts or open sores.

## 2.3 THE ENVIRONMENT

### 2.3.1 CYCLES IN THE BIOSPHERE

- a. Biosphere is the portion of the earth in which all known life forms exist. It consists of the atmosphere, hydrosphere, lithosphere, cryosphere and astrosphere.
- b.

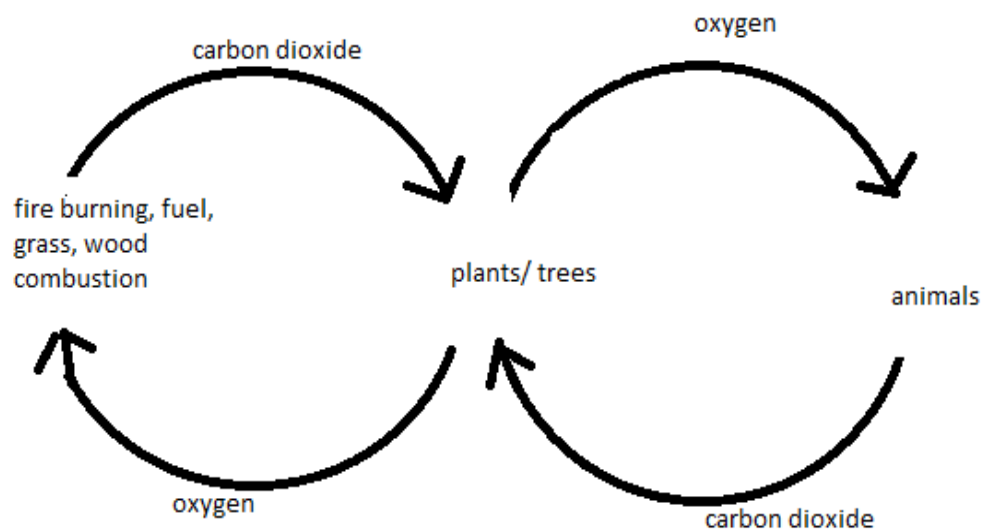

*EXPLANATION*

Plants use carbon dioxide coming from animals and the combustion of fuel, grass, wood and fire burning. The carbon dioxide is used by plants in the process of photosynthesis in which oxygen is produced.

Animals use oxygen coming from plants and give out carbon dioxide during respiration.

Plants that die and buried turn into fossil fuel after many years. When these are burnt, carbon is released into the atmosphere as carbon dioxide.

- c. Factors that affect oxygen and carbon dioxide cycles.
- i. Geological process: processes like volcanic eruptions and other natural changes can result in large quantities of carbon being released into the atmosphere.
  - ii. Human activities: industries burn fuel releasing the carbon compounds that were stored in the coal, oil and other gases. Human activities have increased carbon dioxide influencing global warming and climate change.
  - iii. Clearing of vegetation: clearing of vegetation that serves as carbon sinks has increased the concentration of carbon dioxide in the atmosphere.

*QUESTION TWO*

- a. Nitrogen fixing
- b. Leguminous plants
- c. By planting leguminous plants such as beans and peas. These plants have the ability to take nitrogen from the atmosphere and change it into nitrates which can be used by plants. He can also use artificial fertilizer which contain nitrogen

and ammonium nitrate. Animal manure such as farm yard or cow dung can also be used.

### **2.3.2 WATER MANAGEMENT**

- a.
  - i. To satisfy basic needs.
  - ii. For economic development
  - iii. For sustenance of the natural environment.
  - iv. To support recreational activities.
- b. Water management is the management of water resources under set policies and regulations.
- c.
  - i. Dams and reservoirs are constructed to store water. The water is used in the generation of electricity or as a water supply for town and communities living nearby. This water can also be used in irrigation of crops.
  - ii. Water purification plant  
water purification is the process of removing undesirable chemicals, biological contaminants, suspended solids and gases from contaminated water.
- d. Flow chart

### **QUESTION TWO**

- a.
  - i. Hydroelectricity
  - ii. Turbine
  - iii Geothermal

### **QUESTION THREE**

- a. Purification of water
- b. Filter
- c.
  - i. To ensure there is constant supply of water
  - ii. To ensure the quality of water being supplied is good enough to prevent water-borne diseases in humans.
- d. River, well, dams, hand pumps, lakes, canals, etc.
- e. Boiling
- f. Diarrhoea, typhoid fever, cholera, salmon era, yellow fever, hepatitis A, etc.

### **2.3.3 CONSERVATION OF ANIMALS AND PLANTS**

- a. Domestication is the process of converting animals or plants for domestic or home use. Therefore, domesticated animals and plants are those animals and plants that have been converted and termed for home use.
- b.
  - i. Wild life refers to undomesticated animal species which includes plants, fungi and other organisms.
  - ii. Extinction is defined as the complete elimination of a given species on earth.
  - iii. Conservation is the act of protecting or preserving something from extinction.
- c. Examples of domestic animals are: sheep, goat, cow, donkey, chicken, dog, etc.  
Examples of domestic plants are: maize, tomato, wheat, etc.

- d. Domestic breeds can be improved by cross breeding, outbreeding, cross pollination and grafting.
- e. Animals: black rhino, dodo birds, gorillas, elephants, white rhino, hippopotamus, African wild dogs, large antelopes.  
Plants: African sausage tree, mutondo, African teak, mubanga, mutondo, mukuki, saddle wood, etc.
- f. It is important to protect wild life as source of food and shelter. It is also important for the benefit of the country's economy. It also helps in the maintenance of biodiversity.
- g.
  - i. protecting the natural habitat. This is done by avoiding any form of distruction such as bush fire and deforestation.
  - ii. Setting up artificial sanctuaries like zoo and ranches.
  - iii. Educating people about the importance of protecting endangered wild animals and plants as well as their habitat also helps to protect them.
  - iv. Prevention of poaching by conducting anti-poaching and wildlife crime training aimed at stopping poachers.
  - v. Implementation of conservation laws. The law protects animals and plants by prohibiting the killing, capturing and trading of animal parts as well as destruction of forests.

### **2.3.5 PHOTOSYNTHESIS**

#### *QUESTION ONE*

- a. Photosynthesis is the process by which green plants make their own food in the presence of sun light trapped by chlorophyll.
- b. Sunlight, chlorophyll and temperature.
- c. Glucose and oxygen
- d.
  - i. Photosynthesis takes place only in plants while respiration takes place in both plants and animals.
  - ii. The process of photosynthesis uses carbon dioxide while respiration uses oxygen.
  - iii. Photosynthesis takes place during the day time while respiration takes place during day and night time.

#### *QUESTION TWO*

- a. To de- starch the plant/ remove starch.
- b. Oxygen/ oxygen is used for respiration.
- c. Water molecules gain kinetic energy (the energy in motion) thereby causing them to be moving at a faster rate.
- d. Brings about the balance in the levels of carbon dioxide and oxygen due to the fact that plants use carbon dioxide and releases oxygen as a by-product.
- e. Both plants and animals use oxygen during the night. This brings about a competition for the commodity (oxygen), and so animals may suffocate.

### **2.3.6 TRANSPIRATION**

#### *QUESTION ONE.*

- a. Transpiration is the loss of water vapour by a plant through the leaves.

- b. Factor affecting the rate of transpiration:
- I. Temperature: is the degree of hotness or coldness of a substance. When the temperature is high, water molecules are heated and gain kinetic energy making them to diffuse at a faster rate. Therefore, the higher the temperature, the higher the transpiration rate.
  - II. Humidity: is the amount of water vapour in the air. When the humidity is high in the atmosphere, it has low ability to absorb water from the leaves. Therefore, the higher the humidity, the lower the transpiration rate.
  - III. Wind: this is the moving air. When it is windy, more water molecules are swept away from the leaves forcing more water to diffuse out. Therefore, the greater the wind, the higher the transpiration rate.
  - IV. Light: is the dimness or brightness of a substance. In bright light environment, leaves tend to have wide opened stomata forcing more water molecules to diffuse out. Therefore, the higher the light intensity, the greater the rate of transpiration.
- c.
  - i. They have sunken stomata.
  - ii. They have needle shaped leaves.
  - iii. Dropping of leaves when the water table is low.
- d. Transpiration is important in the sense that it is a means of cooling in plants.
- e.
  - i. anhydrous copper sulphate
  - ii. cobalt chloride paper
  - iii. from the leaves.
- f.
  - i. Photometer
  - ii. Transpiration
  - iii. Indirectly by measuring the distance the water drops in the graduated tube over a measured length of time.  
Indirectly by measuring the reduction in mass of the photometer over a period of time.
  - iv. The photometer does not measure the rate of transpiration accurately because not all of that is taken by the plant is used for transpiration. A twig may not be active for an long time.
  - v. When a twig is cut from a plant, it should be immediately put under water. This prevents entry of air into the xylem vessel.
  - ii. the conditions of the photometer other than the alteration that is being tested should not be changed during a test.

## 2.5.0 MATERIALS AND ENERGY

### QUESTION ONE

- a. Chemical reactions is a process that involves the changing of a substance into a new one that has a different chemical identity. During this reaction, there is emission of heat and light.
- b.
  - i. Synthesis: this is a reaction in which two or more substances combine to form a new compound.  $A+B \dots\dots\dots AB$
  - ii. Decomposition (breaking down): This is a reaction in which a single compound under goes a reaction (break down) to form two or more simpler substances.  $AB \dots\dots\dots A+B$

iii. Single displacement reaction: this is a reaction where one element replaces a simpler element in a compound.  $AB+C \dots\dots\dots A+BC$ .

iv. Double displacement: This is a reaction in which the ions of two compounds exchange places in aqueous solution to form a new compound. An aqueous solution is a solution in which the solvent is water.  $AB+CD \dots\dots\dots AD+CB$

- c. i. Endothermic is a type of reaction that takes in energy from the surroundings.
- ii. Exothermic reaction is the type of reaction that releases energy to the surrounding.
- d. The law of conservation of matter states that in chemical reaction, the total mass of the product must equal the total mass of the reactants, that is, the total mass of a substance before a chemical reaction is equal to the total mass of the substance that are produced.

### 2.5.3 REFLECTION AND REFRACTION OF LIGHT

#### QUESTION ONE

- a. i. Reflection is the bouncing back of light.
  - ii. Ray of light is the path where light passes/ path followed by light.
  - iii. Normal is the line drawn perpendicular to the surface.
  - iv. Reflected ray is a path followed by light after striking the surface.
  - v. Incident ray: Is a path followed before it strikes a surface of the next medium.
- b. The law of reflection states that the incident, reflected ray, and the normal and the normal to the surface of the mirror all lines in the same plane.
- c. Angle of reflection
- d. Angle of refraction
- e. Refracted ray.

#### QUESTION TWO

- a. convex.
- b.

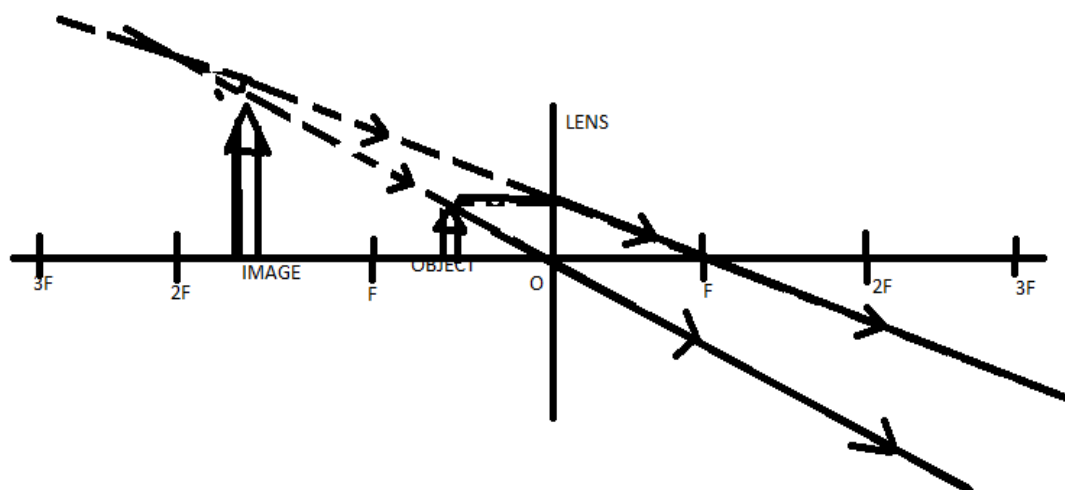

*QUESTION THREE*

a. C

*QUESTION FOUR*

a. Reflection

b. i. PO = Incident ray                      ii. OQ = Reflected ray.

c.  $\text{PON} = 40^\circ = \text{NOQ} = 40^\circ$ ,     $Q = 90^\circ - 40^\circ = 50^\circ$

*QUESTION FIVE*

a. Refraction of light

b. i. The ruler appears to be bent. (ii). The ruler appears to be shallower than really is.

c. Refraction of light. Different colours refracted at different angles forming a spectrum of colours.

d. i. a glass prism                      ii. Mirror and water in a dish.

e. A second triangular prism can be used to combine the different colours of the spectrum to form white light. The second prism of the same size as the first one is placed in an inverted or reversed form.

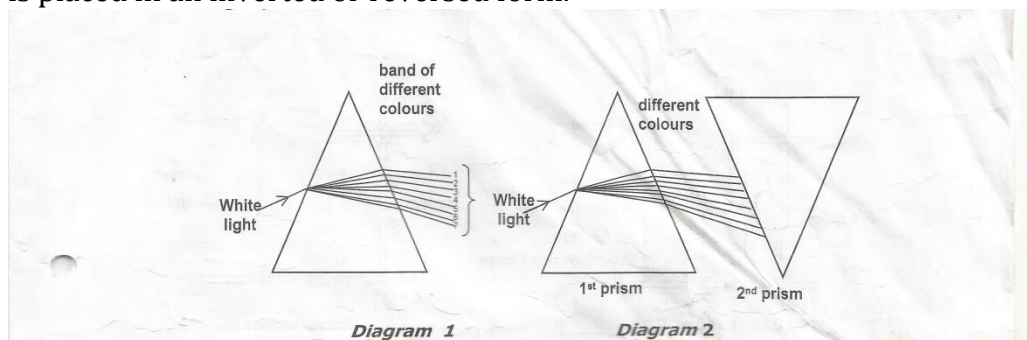

*QUESTION SIX.*

a.

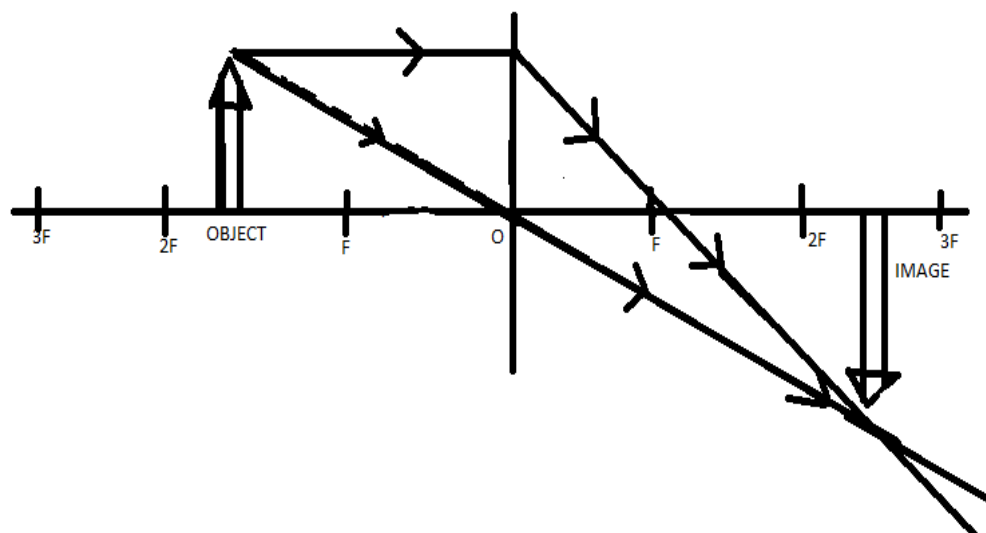

- b. The rays of light entering the droplets of water suspended in the atmosphere are refracted and dispersed. This leads to the formation of a spectrum. Note that the rainbow is produced in the same way the light spectrum is produced by the glass prism.
- c. At sunset or sun rise, light travels a much greater distance through the thicker part of the atmosphere than at mid- day. Red light which has a much stronger penetrating power easily pass through this greater distance and reaches us while the blue light which has less penetrating power is scattered by the dust particles and fails to reach us.
- d. A filter is a transparent material that absorbs some light and allows others to pass through. When white light shines on a coloured filter, all the colours in the white light that forms the spectrum will be absorbed apart from the colour of light similar to the filter will be reflected to our eyes.  
For example, when white light shines on a green colour, the filter absorbs red, orange, yellow, blue, indigo and violet wavelengths of light. Only the green wavelength passes through to the other side of the filter and will be seen as colour green.

## 2.5.4 ELECTRIC CURRENT AND VOLTAGE IN CIRCUIT

### QUESTION ONE

- a.
  - i. Electric current is the measure of how much electric charge flows through a circuit over a period o time.
  - ii. Voltage is a measure of the differences in electrical energy between two parts of a circuit.
  - iii. Electric circuit is the path where electric current flows.
- b. Electric current is the rate at which charge is flowing while voltage is the difference in charge between two points.
- c.

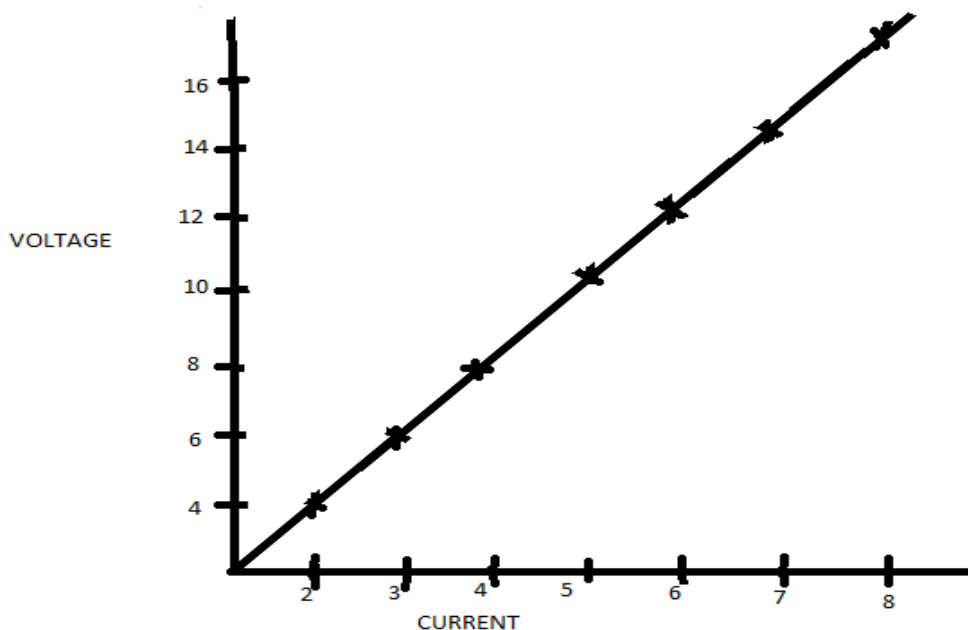

- d.
- e. i. Ohm's law states that the current flowing through an electrical conductor is proportional to the potential differential between two ends of the conductor provided the temperature is the same.
- ii. Voltage is direct proportional to current.
- iii. 5.0 Volts.
- iv.  $R=V/I$ ,  $R=4.0V/2.0I$ ,  $R=2.0$

**QUESTION TWO**

- a. H=Anode, I=Cathode
- b. Makes water to become a good conductor of electricity.
- c. It puts of a flame with a pop sound .
- d.
- e.  $H_2O \dots\dots\dots H_2 + O_2$

**QUESTION THREE**

- a. Arranged in series.
- b. There are four cells each having 2.5V. Therefore  $2.5V \times 4 = 10V$ .
- c. i.  $R=V/I$ ,  $R=10V/5A$ ,  $R=2$  ohms.
- ii.  $R=6V/5A$ ,  $R=1.5$  ohms.
- d.  $P=VI$ ,  $P=5A \times 10V$ ,  $P=50$  Watts.

**QUESTION FOUR**

- a. Z
- b. The value of Y will increase.
- c. The voltage and current are direct proportional to each other, that is, when voltage increase also increases.
- d. 5V.  
According to the graph, resistance is 2 ohms and it is constant. Therefore,  
 $V=IR$ .  $2.5A \times 2 = 5V$

**QUESTION FIVE**

- a . Ammeter(the ammeter measures the current flowing in the circuit)
  - b . Voltage.
  - c. .i. The conclusion is that current flowing through the circuit is directly proportional to the voltage.
  - li . The voltage is 5V.
- $P=VI$ ,  $P= 5V \times 2.5A$ ,  $P= 12.5$  Watts.
- d..  $R=V/I$ ,  $R=5/2.5$ ,  $R=2$  ohms.

### 2.5.5 PRESSURE

#### QUESTION ONE

- a. Pressure is the amount of force acting per unit area of a surface.
- b. Pressure=Force/Area,  $p=F/A$
- c. Temperature, Volume, the number of gaseous particles in a container.
- d. i. Sharp knife  
ii. A sharper knife cuts with easy because it has a small surface area and requires a little force to cut through an orange. The smaller the surface area, the higher the pressure and vice-versa.

#### QUESTION TWO

- a.  $400\text{cm}/100= 40\text{m}$ .  $200\text{cm}/100 = 20\text{m}$ .  
 $A = (L \times B)^2$ ,  $A = (40.0\text{cm} \times 20.0\text{cm}) = 80.0\text{m}^2$
- b. Using the formula for pressure  
 $P= 80.0\text{N}/80.0\text{m}^2$ ,  $p=1\text{N}/\text{m}^2$
- c.  $F=400\text{N}/\text{m}^2 \times 2.0 \text{m}^2 = 800.0 \text{N}$

### 2.5.6 ENERGY AND ITS CONSERVATION

- a. Energy is the current for performing work/ energy is the ability to do work.
- b. Kinetic energy, potential energy, chemical energy, electrical energy, heat energy, mechanical energy, sound energy, radiant energy, gravitational, nuclear energy and light energy.
- c. i. chemical energy is changed into kinetic, heat and light energy with the help of electric energy from a battery (combustion of fuels in motor vehicles)  
ii. in the electronic storage battery, chemical energy is converted to electrical energy and later converted to light and sound energy.  
iii. green plants convert light energy from the sun into chemical energy during photosynthesis of starch.
- d. Effects of energy production on the environment:  
I. Depletion of resources: The process of extracting materials such as geothermal fluids for power generation typically derives energy from the natural reservoirs at a faster rate than the rate at which it is replenished.

- ii. Damage to geothermal features: Natural features such as hot spring geysers, steam vents, etc are easily damaged.
  - iii. Global warming and climate change: consumption of fossil fuel resources leads to global warming and climate change.
  - iv. Water pollution: waste are released into rivers or lakes instead of being injected into the geothermal field, these pollutants can damage aquatic life and make water unsafe for drinking and irrigation.
  - v. Wild life and habitat loss: Production of energy may cause habitat destruction. Construction of energy plants destroy the organisms that previously used the sites.
- e. Ways of conserving energy
- i. Replacing light bulbs with fluorescent bulbs or led bulbs.
  - ii. Reducing the use of out- door lights for security purpose.
  - iii. Switching off all the electrical appliances and lighting equipment.
  - iv. Reducing excessive heating and cooking in summer and winter respectively.
  - v. Higher use of renewable energy sources.

## PART TWO

- f. Recycling
- g. Recycling is a series of steps in which a used product is reprocessed, remade and sold as a new product.
- h. Reduce means using fewer resources. You can help towards reducing through the following:
  - vi. By buying products made from recycled materials.
  - vii. By buying products made locally and so less energy is used for transport.
  - viii. By buying products that do not have a lot of packaging.
  - ix. Save water by turning off the tap while you brush your teeth.
  - x. Make double sided photocopies whenever possible.
- i. Examples of products that can be recycled include the following: all types of paper, cardboards, glass, metal canes, all types of plastics, oil, etc.
- j. Ways we can reuse in everyday life include the following:
  - vi. By returning returnable bottles.
  - vii. Use empty bottles, jars, shoe boxes and margarine containers for storage containers.

## 2.5.7 COMMUNICATION

- a. Ways of sending and receiving information:

Radio, cell phones, sms (text message), video conference, telephone, television, E-mail, fax, letters, eye contact, sign language, speech, etc.

b. Radio:

Advantages

- I. It is the cheapest form of media in terms of energy use, weight and cost.
- ii. it caters for illiterate people who cannot read and write but can hear.
- iii. important news and information can be spread to large population easily and fast.
- iv. it reaches a wide audience since almost every one can now afford to buy a radio.

Disadvantages

- I. Radio allows one way communication. The sender can only send information, and in most cases there is no feed back.
- ii. radio can only send audio signals without visual signals.
- iii. Radio signals are susceptible to inference and so it can sometimes be hard to receive a clear signal.
- iv. It is difficult for listeners to refer to necessary information due to lack of permanent reference records such as addresses.

Television

Advantages:

- I. combines sound and picture thus making the communication more effective.
- ii. it has a wide geographical coverage and broad audience.
- iii. it is a good medium for advertisement of business and products.
- iv. it is a very good medium for educational programs

Disadvantages:

- I. It is a very expensive method of communication.
- ii. It is a strong effect on eye sight.
- iii. it requires electricity, hence can not be used in areas where there is no electricity.
- iv. The time spent watching television could be used on something constructive.

Newspaper

Advantages:

- I. Newspapers are relatively cheap to purchase.
- ii. Has the most in depth community coverage.
- iii. Has a strong traditional way of delivering accurate reliable news.

Disadvantages:

- I. little room for participation as one can not give direct feed back to the writer of an article.
- ii. it requires a literate public in order to deliver information.
- iii. they can be used in future for reference.

SMS (text message)

Advantages:

- I. it is suitable for recording messages
- Ii. It is cheaper.
- iii. it is good for communication between family and friends.

Disadvantages:

- I. SMS is restricted only to short messages.

- ii. It is not suitable for official messages such as the work places.
- iii. it requires basic typing skills and literacy.
- iv. It is not suitable for emergency situations.
- c. i. Radio signals.
- ii. A is the receiving aerial which converts the radio signals back to the electrical signals.
- iii. transmitter.
- iv. the signal would be very poor.
- v. the tracking disc receives and tracks down the signals from the intersatellite and sends signals to the main telecommunication transmitters in Lusaka.
- v. Zambia is able to watch international programs from different continents.

## **2.5.8 DIGITAL AND ANALOGUE TRANSMISSION**

### *QUESTION ONE*

- a. Transmission is the act of transferring something from one spot to another like a radio or television signal.
- b. Analogue transmission is a transmission method of conveying voice, data, image, signal or video information using a continuous signal which varies in amplitude, phase or some other property in proportion to that of a variable.

### *QUESTION TWO.*

- a. R: Loud speaker      Q: Transmitter
- b. R: Converts the sound into electrical signal.  
The amplifier makes the signal stronger.
- c. Repeater station, -Transmitters,      - Satellites.

### *QUESTION THREE*

- a. Antenna/ aerial.
- b. The signal received by the TV would be very poor or not clear.
- c. i. Fine tune: is used to pick the signal and choose a channel.
- ii. Loud speaker: converts electrical signal back to sound signal.
- iii. Picture tube: changes the video signal back in to the picture that matches with the original.
- iv. Video speaker: changes audio signal back into sound which match with the original sound made at the station.
- d. Satellite earth station sends and receives signals through a communication satellite. It enables countries to communicate with countries in other continents.
- e. Live broadcasting is the type of media broadcast in real time as a particular event happens while recorded broadcasting is the type of media broadcasting in which a program is recorded and broadcast at a later time.