

Logic circuits

A digital electronic circuit in a computer system is typically made up of thousands of [glossary-inline:glossary-page-||logic-gate "logic gates"]. Each circuit will be designed to carry out a specific function.

Circuits within computer systems can be highly complex so you will start by considering a simple control circuit made up of a few logic gates.

GCSE A simple logic circuit

Start by considering an intruder alarm. The alarm can be set to be armed or unarmed. The alarm will sound if motion is detected and the alarm is armed.

The circuit has two inputs labelled S and M :

- The system (S) will produce a 1 if it is set to armed, otherwise it will produce a 0.
- The motion sensor (M) will produce a 1 if motion is detected, otherwise it will produce a 0.

There is one output:

- An alarm (A), which will sound if it receives an input of 1, otherwise it will remain silent.

A circuit diagram for the alarm system is shown below:

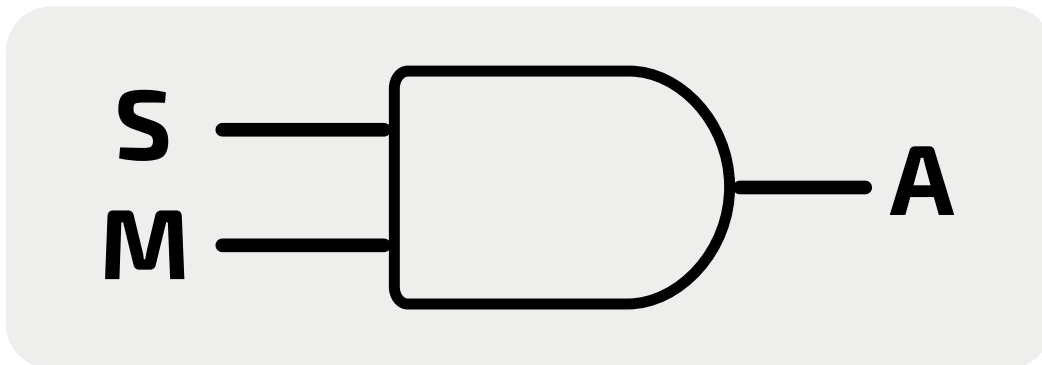

Figure 1: Circuit diagram for a simple alarm system

Here is the truth table for the alarm system, which essentially shows a basic AND gate:

Input S	Input M	Output A
0	0	0
0	1	0
1	0	0
1	1	1

GCSE The circuit's truth table

A circuit has a truth table that reflects the logic of the whole circuit. It shows all possible input signals together with their corresponding output signals.

Consider the circuit diagram for this alarm system.

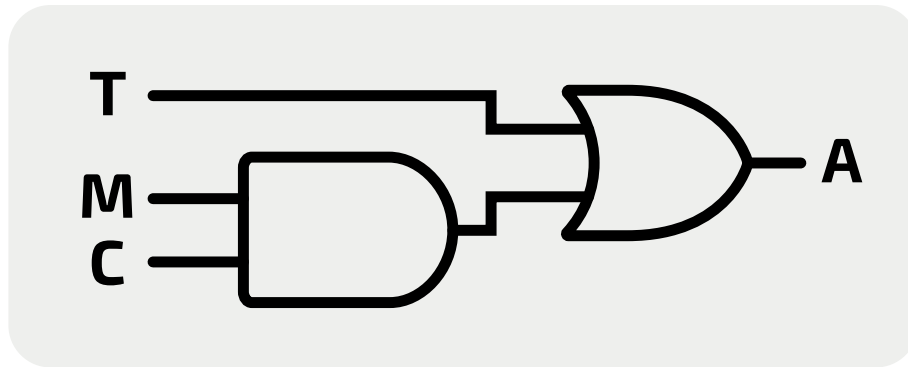

Figure 3: Circuit diagram for a simple alarm system

Here is the circuit's truth table:

Inputs			Output
T	M	C	A
0	0	0	0
0	0	1	0
0	1	0	0
0	1	1	1
1	0	0	1
1	0	1	1
1	1	0	1
1	1	1	1

You can see that there are eight possible combinations of input values. Five of them will result in the alarm sounding. These are the rows — highlighted in the truth table — where the output A is 1.

- When T is 1 (the temperature is above 30°C)
- When M is 1 (the motion sensor detects movement) **and** C is 1 (the clock time is between 20:00 and 06:00)

GCSE The circuit's Boolean expression

Every logic circuit can also be represented by a Boolean expression. A Boolean expression defines the logic for the combination of inputs that **produce an output value of 1**. You saw from the truth table that this occurs when:

- T is 1 (the temperature is above 30°C), **or**
- M is 1 (the motion sensor detects movement) **and** C is 1 (the time is between 20:00 and 06:00)

So, the expression for the circuit is:

$$A = (M \text{ AND } C) \text{ OR } T$$

The operators in the expression can also be written using the algebraic symbols, as:

$$A = (M \wedge C) \vee T$$

Notice that you do **not** write:

$$(M = 1 \wedge C = 1) \vee T = 1$$

The " $= 1$ " is implicit, meaning if we write a letter in an expression, it is automatically understood as a 1. Similarly, if you want to specify " $= 0$ ", you must write $\neg X$ (where X is the variable that needs to have a value of 0).

A Level

A simple logic circuit

Start by considering a circuit that controls an alarm. The alarm will sound if motion is detected and it is between 20:00 and 06:00 hours. It will also sound if the temperature exceeds 30°C , whatever time it is.

The circuit has three inputs labelled T , M , and C :

- The temperature sensor (T) will produce a 1 if the temperature is over 30°C , otherwise it will produce a 0.
- The motion sensor (M) will produce a 1 if motion is detected, otherwise it will produce a 0.
- The clock (C) will produce a 1 if the time is between 20:00 and 06:00, otherwise it will produce a 0.

There is one output:

- An alarm (A), which will sound if it receives an input of 1, otherwise it will remain silent.

A circuit diagram for the alarm system is shown below in **Figure 2**.

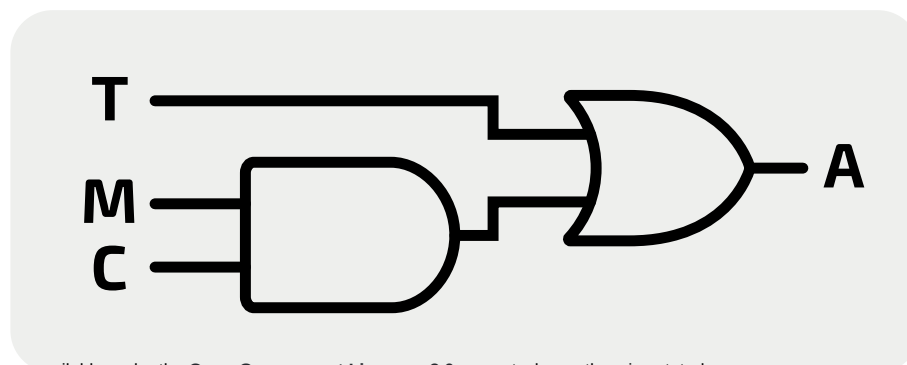

All teaching materials on this site are available under the [Open Government Licence v3.0](#), except where otherwise stated.

Figure 2: Circuit diagram for a simple alarm system